

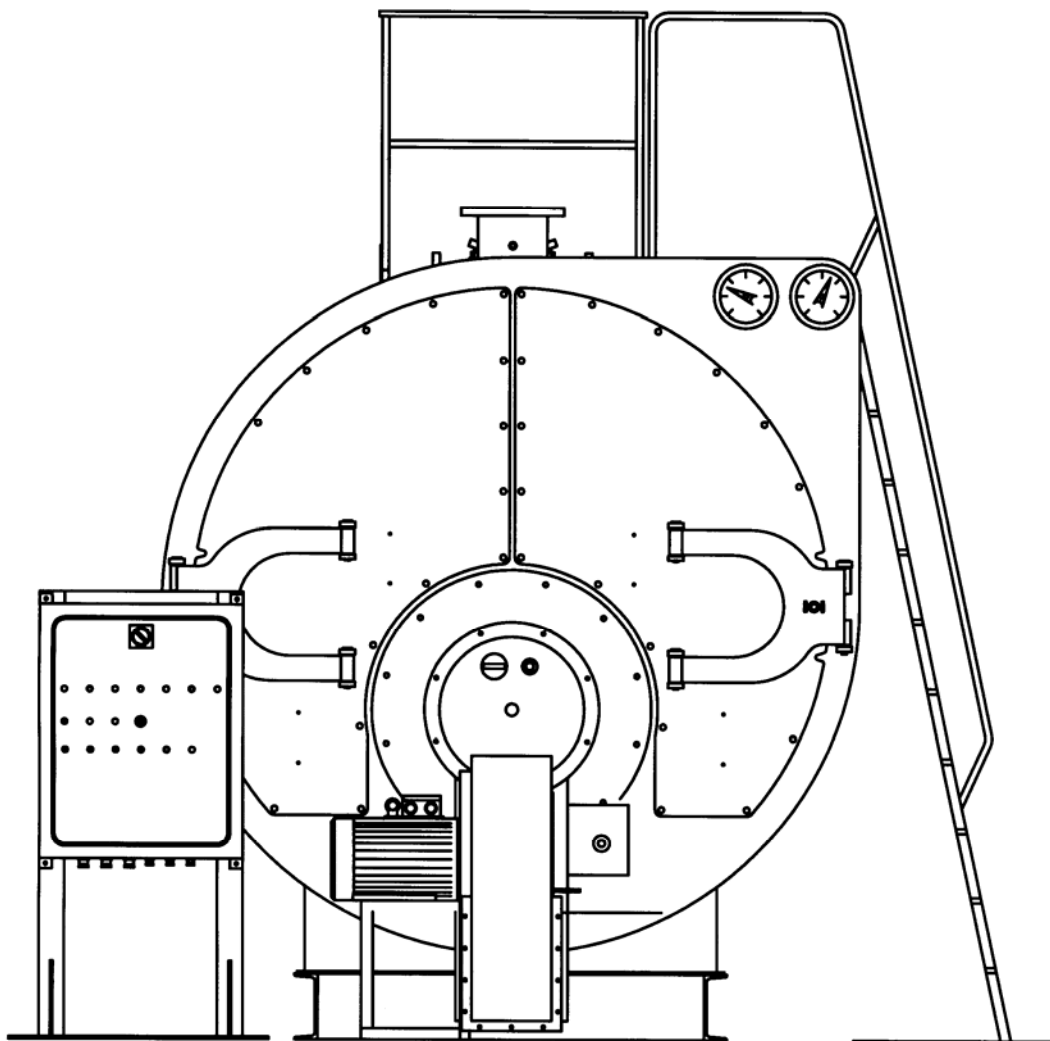

TECHNICAL MANUAL

GB



ASGX

**MEDIUM/HIGH PRESSURE
HOT WATER BOILER**

INDEX

1	TECHNICAL CHARACTERISTICS	2
1.1	GENERAL	2
1.2	TECHNICAL DATA	2
2	ACCESSORIES	3
2.1	PRESSURE.....	3
	Pressure gauge	3
	Operation pressure switch	4
	Safety pressure switch	4
	Safety valves	5
2.2	TEMPERATURE	6
	TEMPERATURE CONTROLLER	6
	THERMOSTATS	9
	Thermometer	9
3	INSTALLATION	10
3.1	THERMAL PLANT	10
3.2	SITING	10
3.3	WATER CONNECTIONS.....	10
3.4	ELECTRIC CONNECTIONS.....	11
3.5	SMOKESTACK	11
3.6	BURNER	11
	Boiler - Burner coupling.....	11
4	STARTING	12
5	MAINTENANCE	13
5.1	ORDINARY	13
5.2	SCHEDULED	13
5.3	CONSERVATION DURING WHEN OUT OF SERVICE	13
	Dry conservation	13
	Wet conservation.....	13
6	WATER CHARACTERISTICS	14
6.1	FEEDWATER - LIMIT VALUES (ENTERING THE BOILER)	14
6.2	BOILER WATER - LIMITING VALUES.....	15
6.3	FREQUENCY OF THE ANALYSES	15
7	FAULTY OPERATION	16

1 TECHNICAL CHARACTERISTICS

1.1 GENERAL

The medium/high pressure hot water boiler are semiportable horizontal heaters with fire tubes suitable for pressurised combustion.

1.2 TECHNICAL DATA

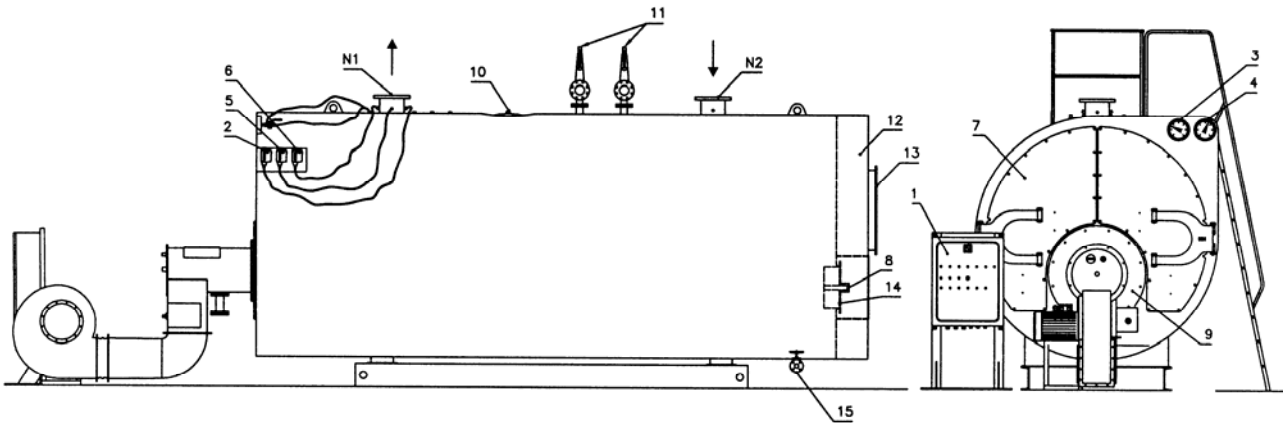

Fig. 1

LEGEND

1	Switchboard	11	Safety valves
2	Pressure switch	12	Rear flue gas chamber
3	Thermometer	13	Smokestack connection
4	Pressure gauge	14	Cleaning door
5	Modulating thermostat	15	Drain unit
6	Safety thermostat	N1	Flow
7	Front door	N2	Return
8	Flame inspection hole	N3	Safety valves drain
9	Burner plate		
10	Inspection door		

2 ACCESSORIES

The medium/high pressure hot water boiler are fitted with a series of accessories that can be subdivided as follows:

- Safety accessories (safety valves, safety pressure switches, safety thermostat)
- Observation accessories (temperature gauges, pressure gauge, flame inspection)
- Control accessories (thermostat)

In the following description the accessories are subdivided as to the physical parameter they control (pressure and temperature).

2.1 PRESSURE

PRESSURE GAUGE (Fig. 2)

The pressure gauge is Bourdon type consisting of a flat elliptical section metal tube, bent to an arc. One end of the tube is open and communicates with the boiler where the pressure is to be measured; the other end, closed and free to move is connected by a lever system to a toothed arc and to the gauge indicator hand.

The gauge shows in red the design pressure.

The gauge is carried on a three-way valve to allow the following operations:

- Communication between boiler and gauge (normal operation position)
- Communication between gauge and the atmosphere (position necessary to purge the siphon)
- Communication between the boiler, the gauge and a test gauge (position necessary to verify the gauge)



Fig. 2

OPERATION PRESSURE SWITCH

Device that controls the boiler pressure and holds the pressure between the set maximum and minimum values.

Instructions for adjustment.

The electric switch has three screws (2-1-3 from right to left).

On reaching the set pressure, the contact 2-1 switches to 2-3.

Adjustment of the pressure switch (Fig. 3):

- a) Turn the knob (1) until the scale indicator (2) reaches the pressure at which the burner shall restart;
- a) Remove the cover of the pressure switch and position the drum (3) at the value selected for the pressure differential (stopping the burner) as to the diagram Fig. 4.

Example:

- * Type of pressure switch: RT 5
- * Scale indicator: 9 bar
- * Drum indicator: 4 corresponding to 2,1 bar
- * Burner start: 9 bar
- * Burner stop: 11,1 bar

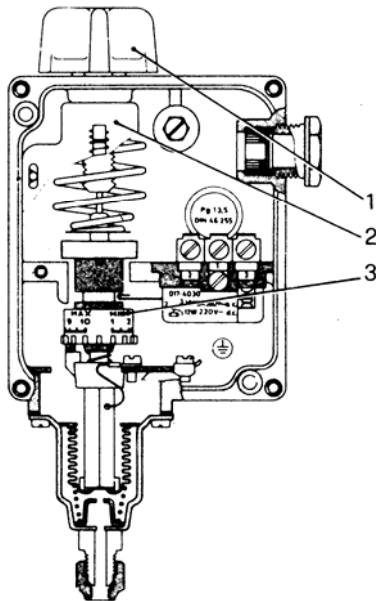

Fig. 3

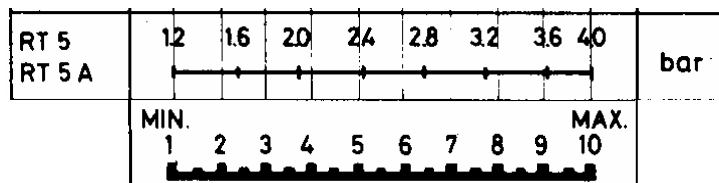

Fig. 4

SAFETY PRESSURE SWITCH

This switch is set at a higher pressure than the maximum of the control pressure switch, but always lower than the opening pressure of the safety valves.

The safety pressure switch acts in the case of a fault to the control pressure switch and stops the burner permanently. Restarting the burner can only occur after the water pressure has fallen and after a manual reset on the switchboard.

This pressure switch is adjusted in a similar manner to that of the control pressure switch, with the only precaution that the drum indicator is set to 1 so that the differential is effectively nil.

SAFETY VALVES

These valves have the function of discharging medium/high pressure hot water boiler water when the maximum design pressure of the boiler is reached.

The valves used on boilers are of the type **Spring** (Fig. 5).

The boiler operator must pay much attention to the safety valves and carry out careful and diligent maintenance. The safety valve is the most important and sensitive accessory on the boiler and represents the best guarantee that the internal pressure of the boiler does not exceed the design pressure.

As during normal operation of a boiler, the safety valve never acts, it is **good practice to check that the valve is free, i.e. that the valve plug is not stuck to the seat**, by acting on the side lever until the valve starts to discharge water.

WARNING

On first start-up, you must verify that safety valve adjustment is made to the boiler design pressure. Generally the spring safety valve is supplied already adjusted,

The safety valve installed on boilers must have the discharge piped to outside the boiler room. Particular care must be taken in designing the discharge line; we show some here.

- The discharge line should be of diameter at least equal to that of the discharge flange on the safety valve.
- Only wide radius curves must be used in the discharge line.
- The entire discharge line must be built to avoid the formation of condensation locks. There must be therefore adequate slopes to ensure complete drainage.

Particular care must be taken if the valve seat and plug are to be ground; if this operation becomes necessary due to leaks, use abrasives based on silicon carbide or oil based carborundum. Carry out the first grinding operation using fine grain abrasive, finishing with a very fine grain abrasive.

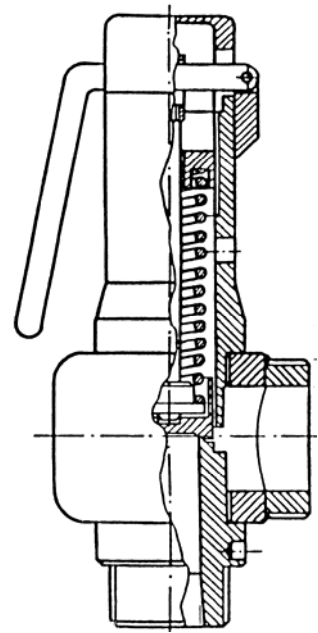
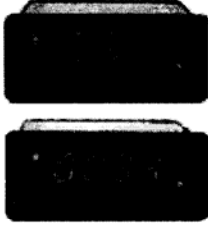

Fig. 5

2.2 TEMPERATURE

TEMPERATURE CONTROLLER

1. FACEPLATE DESCRIPTION



LED	FUNCTION
M	Uscita Principale Main Output
I	Uscita Allarme I Alarm I Output
II	Uscita Allarme II Alarm II Output
- DEV +	Indicatore scostamento Deviation Indicator
°C / °F	OFF = °C ON = °F
LK	Chiave Accesso (Lock) Access code (Lock)
AT	Autoregolazione Self-tuning

KEY	FUNCTION	DISPLAY	FUNCTION
[Function Key]	Tasto Funzione Function Key	PV	Valore di Processo Process-Value
[Increment Key]	Tasto Incremento Increment Key	SV	Valore Impostato Set-Value
[Decrement Key]	Tasto Decremento Decrement Key		
[Reverse Key]	Tasto di Ritorno Reverse Key		

2. MODELS

MODEL	TJ2x	TJ3x	TJ34	TJ43	TJ44	TJ46	TJ48	TJ63	TJ64	TJ66	TJ68	TJ74	TJ78	TJ84	TJ88	TJ94	TJ98	TJxx
3 DIGIT + DEV.																		
3 + 3 DIGIT																		
4 DIGIT + DEV.																		
4 + 4 DIGIT																		

3. DIMENSIONS unit = mm

MODEL	A	B	C	D	E	F	G	H	I
TJ2x	45	24	6	62	-	71	29	111	48
TJ3x	74	32	6	62	-	71	29	111	48
TJ4x	48	48	5	72	13	45 ^{+0.4}	45 ^{+0.4}	72	72
TJ6x	48	96	9	55	10	45 ^{+0.4}	92 ^{+0.8}	72	154
TJ7x									
TJ8x									
TJ9x									

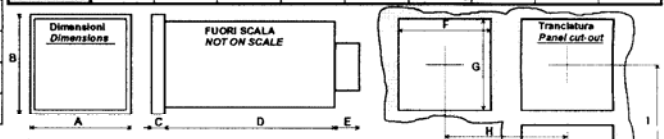

4. TECHNICAL DATA (see data catalog for details)

INPUTS

- RTD Pt100 according to DIN 43760 (linearize d) three wires connection for RTD Pt100 (line - 100hm max).
- Thermocouple J or K according IEC584-1 (linearized) automatic compensation ref. junction for thermocouples.
- Continuous mV range 0 + 50mVdc with prog. display (other values ie. 0+1V, 0+5V, 0+10Vdc by ext. resistors).
- Continuous mA range 0 + 20mAdc with prog. display (supplied 2.5 ohm resistor, must be connected externally).
- Floating input (e.g. sensor breaking) makes overrange.

OUTPUTS

- MAIN : relay SPDT 3A @ 250Vac max; or logic output 12Vdc 20% Ri=270R 2W on req. dc out 0+20mA or 4+20mA or 0+1V or 0+5V
- LIMIT I : relay SPDT 3A @ 250Vac max; (SPST x TJ3x) or logic output 12Vdc 20% Ri=270R 2W

POWER SUPPLY

24 or 115 or 230 Vac ±10% (transformer)

Supply frequency : 50 - 60 Hz.
Power : 3 Watt max

CONNECTIONS

- TJ3x 2 x 5 poles screw connectors (2.5mm).
- TJ4x "UNDECAL" for socket with screw connections.
- TJ6x 11 poles s.r. disconnecting terminal block with screws.

5. CONNECTIONS DIAGRAM & WIRING

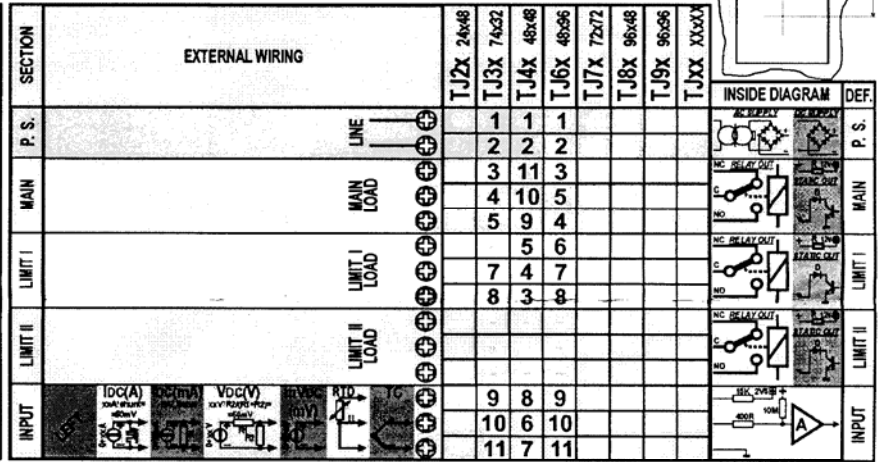

6. FLOW DIAGRAM

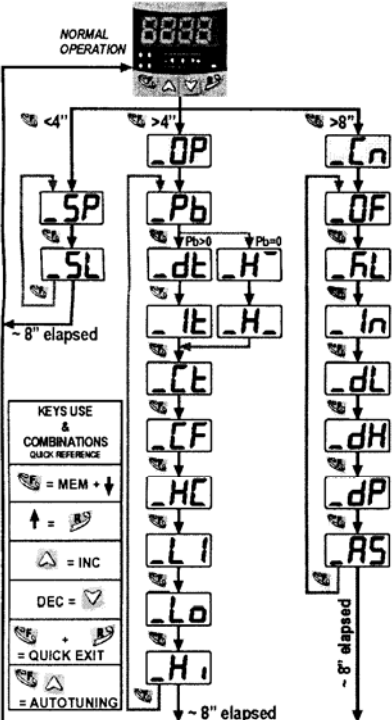

7. ELECTRICAL CONNECTIONS

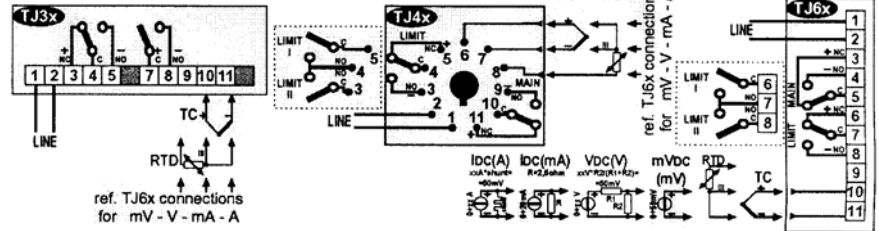

8. INPUTS and RANGES

CODE	INPUT	3 digit (TJx3 or TJx6)				4 digit (TJx4 or TJx8)			
		min°C	MAX°C	min°F	MAX°F	min°F	MAX°F	min°F	MAX°F
0	Pt100	-199°C	500°C	-199°F	932°F	-199°C	500°C	-328°F	932°F
1	Pt100	-19.9°C	99.9°C	-	-	-199.9°C	400.0°C	-	-
2	Tc 'J'	0°C	900°C	0°F	999°F	0°C	900°C	0°F	1652°F
3	Tc 'K'	0°C	999°C	0°F	999°F	0°C	1300°C	0°F	2372°F
4	mV-mA	-199pts	999pts	-	-	-1999pts	9999pts	-	-

9 HYSTERESIS DIAGRAM

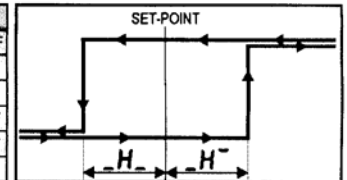

10. ALARM FUNCTIONS (ALARM = LIMIT)

CODE	ALARM (LIMIT) OUTPUT ACTION	RELATIVE	DIRECT
0	MAIN SET POINT	main +/- limit	ABSOLUTE
1	Limit S.P.	main + limit	RELATIVE
2	Limit S.P.	main - limit	RELATIVE
3	Limit S.P.	main +/- limit	ABSOLUTE
4	Limit S.P.	main + limit	RELATIVE
5	Limit S.P.	main + limit	REVERSE
6	Limit S.P.	main - limit	REVERSE
7	Limit S.P.	main +/- limit	ABSOLUTE
8	NO ALARM		

11. ERROR MESSAGE

Errors Code	Message
000	Over range
UUU	Under range

PROGRAMMING MANUAL

FUNCTION KEYS DESCRIPTION (see FLOW DIAGRAM)		Note: * = 4 digit display
F key	- allows to access to loops 1, 2 and 3 (pressing it for different time intervals) - allows to display parameters (in Tjx3 and Tjx4 alternatively with parameter value) - stores the displayed value, independently if modified or not	888 RANGE DEFAULT
R key	goes back to previous parameter, discarding any eventual modification	
F + R keys	immediate exit. Return to normal operation condition (as to wait for 8" elapsed)	
▲▼ keys	allow respectively to increase and to decrease the displayed value	
Loop 1 - SET-POINT PARAMETERS : press F for less than 4"		
Main SET-POINT To enter the Set-Point MAIN adjustment, press the F key (for less than 4"). The required value is set through ▲▼ keys. Store by pressing the F key within 8". Then access is made to LIMIT Set-Point parameter.		_SP Lo + Hi 50 pts
Limit SET-POINT * -1999 9999 The required value is set through ▲▼ keys. Store by pressing the F key within 8". The alarm intervention point and its performed function have different meanings depending on the selected type of alarm (see ALARM FUNCTIONS). The intervention hysteresis is fixed and equal to -2pts.		_SL -199 + 999 50 pts
Loop 2 - OPERATOR PARAMETERS : press F for 4" ÷ 8"		
Group of parameters to be set depending on the process the instrument shall work with PROPORTIONAL BAND (P.B.) If P.B. > 0 this will determine a PID control mode and the two following parameters are the derivative (dt) and the integral (It) action times. If P.B. = 0 this will determine an ON-OFF working mode, i.e. The controller acts like a thermostat, and the two following parameters are the upper and lower hysteresis ranges.		_OP _Pb 0 + 999p 100 pts
ON-OFF Mode (P.B. = 0)		PID Mode (P.B. > 0)
UPPER HYSTERESIS Together with lower hysteresis, it represents the differential of intervention (hysteresis) over and under the Set-Point. It is located over the Set-Point.	_H 0 + 100p 10 pts	DERIVATIVE TIME It identifies the "anticipating" feature in the behaviour of a controller. <u>Setting it at zero, the derivative action is excluded.</u>
LOWER HYSTERESIS Together with upper hysteresis, it represents the differential of intervention (hysteresis) over and under the Set-Point. It is located under the Set-Point.	_H 0 + 100p 4 pts	INTEGRAL TIME It identifies the "nulling" feature in the behaviour of a controller. <u>Setting it at zero, the integral action is excluded.</u>
CYCLE TIME It is the output (relay, logical or continuous) cycle time: typical value for logical or continuous output is 1" while for relay output it is 10". During a cycle, the power calculated by the controller is supplied all at once, first ton, then toff. Example: Power to be supplied=20%, cycle time=10" ==> t.on=2", t.off=8".	N.B. Operative only if P.B. is > 0.	
°C/°F SELECTION This parameter allows to select the measurement unit to work with: °C or °F The frontal indicator (°C/°F led) shows the current selection. If turned off, you are working with °C, if turned on you are working with °F. The relationships between the two measurement units are: °F=(°C x 9/5)+32 and °C=(°F-32) x 5/9	_Ct 1 + 100" 1" or 10"	
HEATING/COOLING FUNCTION The HEAT / COOL function allows to select the behaviour of the MAIN output of the controller. There are two available choices: H = HEATING : MAIN output is active with input values lower than Set-Point. C = COOLING : MAIN output is active with input values higher than Set-Point.	_CF °C / °F °C	
ALARM TYPES (LIMIT) The corresponding code of the selected alarm type is displayed (see ALARM FUNCTIONS table). 9 alarm types are available, to be set from 0 to 8, through ▲▼ keys. The alarm type (limit) determines the alarm output (limit) behaviour depending on the values of Limit Set-point, Main set-point and input variable.	_HC H / C H	
MIN MAIN SET-POINT * -1999 9999 The minimum Main Set-point value restricts the lowering of the Main Set-point so that the user will not be able to set lower values than this limit. Default value is 0°C. If a range with a lower initial scale value is selected (see INPUTS and RANGES table), modify this parameter manually. N.B. Comply with Lo lower than Hi (Lo < Hi)	_LI 0 + 8 8	
MAX MAIN SET-POINT * -1999 9999 The maximum Main Set-point value restricts the increasing of the Main Set-point so that the user will not be able to set higher values than this limit. Default value is 500°C. If a range with a higher full scale value is selected (see INPUTS and RANGES table), modify this parameter manually. N.B. Comply with Hi higher than Lo (Hi > Lo).	_Lo -199 + 999 0 pts	
	_Hi -199 + 999 500 pts	

Loop 3 - CONFIGURATION PARAMETERS : press F for more than 8"		-Ln
Group of parameters to be set depending on the application where the controller is used.		
OFFSET		-OF
The first configuration parameter is the Offset.		
The value here set will be algebraically added to the input measured value.		
Thanks to this parameter, it is possible to correct the displayed measure by a fixed value.		-100 + 100
Example: manual alignment of the measure to different references or among different transducers.		0 pts
SECURITY LOCK Pressing the F key after Offset, access is made to the security lock setting.		-RL
0 = disabled lock, all parameters setting allowed.	Led "LK" = OFF	0 + 3
1 = "Configuration parameters" setting locked.	Led "LK" = OFF	0
2 = "Configuration parameters" and "Operator parameters" settings locked.	Led "LK" = ON	
3 = fully enabled lock, all parameters setting disabled.	Led "LK" = ON	
INPUT and RANGES		-In
Access is made to the input type, with the related range setting.		0 + 4
Details, relative limits and correspondence codes are available in the INPUTS and RANGES table.		2
MINIMUM VISUALISATION (for linear inputs only: code=4) * -1999 + 9999		-dL
Working with linear inputs (0+20mA, 0+50mV, ...), the minimum input value must be related to the corresponding visualisation (e.g.1 0mA = 000pts e.g.2 0mV = 000pts).		-199 + 999
The value of this parameter shall always correspond to the theoretical zero of the input variable (with 4+20mA input, the value corresponding to 0mA must be set).		0 pts
MAXIMUM VISUALISATION (for linear inputs only: code=4) * -1999 + 9999		-dH
It defines the displayed value corresponding to the maximum of the process variable.		-199 + 999
Working with linear inputs (0+20mA, 0+50mV, ...), the maximum input value must be related to the corresponding visualisation (e.g.1 20mA = 500pts e.g.2 50mV = 800pts).		999 pts
eg.1 0+20mA display 0+100pts: dL=0, dH=100 eg.2 4+20mA display 0+100pts: dL=-25, dH=100.		
DECIMAL POINT POSITION (for linear input only: code=4) * 0 + 3		-dP
This parameter determines the decimal point position as follows:		0 + 2
0 = 0 + 999	* 0 = 0 + 9999	0
1 = 0 + 99.9	* 1 = 0 + 999.9	
2 = 0 + 9.99	* 2 = 0 + 99.99	
	* 3 = 0 + 9.999	
ANTI-RESET WINDOW		-RS
It represents the P.B. extension over the Set-Point, within the limit of the integral action.		0 + 100%
Its value is expressed as a percentage with reference to the P.B.		10%
A careful use of this function allows to decrease significantly the overshoots, a typical integral action effect, without invalidating the system accuracy.		

SPECIAL FUNCTIONS

SELF TUNING Led 'AT'. Function that is activated or de-activated by pressing the F key with ^ key. It allows the instrument to calculate the most appropriate values of controlling parameters (P.b., dt, It). It uses advanced and sophisticated not intrusive algorithms. To obtain an effective Self Tuning intervention we suggest to activate it from the very beginning of the heating process. It is automatically de-activated when its task is finished or when the controller doesn't find conditions to calculate new parameters values consistently.

SIMPLIFIED INSTRUCTIONS FOR TEMPERATURE CONTROLLER

The controller is supplied partially set-up.

The working temperature and the high limit temperature must be set-up.

Temperature setting:

_SL = working temperature (setting of second stage of the burner – high)

_SP = high limit temperature (burner on/off)

Note: if the buttons are not pressed for 8 seconds, the controller will pass automatically from setting mode to display mode.

Press F for 1 second, _SP will appear on the display and it flashes with set-up value, alternatively. Example; “115” (°C). (_SP→115→_SP→115→_SP→115.....)

Using the buttons increments “▲” or decrement “▼” set the requested temperature value and then press “F” to confirm the value.

Automatically will appear on the display “_SL” (high limit setting), set the high limit temperature as the previous description, (▲▼), at the end of the setting press “F” to confirm.

After 8 seconds, without pressing any bottoms, the controller will pass in display mode. For further setting modifications, use the enclosed instructions.

Hysteresis values, factory set up:

Hysteresis on “SP” boiler limit temperature (setting of second stage of the burner)

If the read temperature is over the working temperature set up plus the hysteresis value (3°C) = OFF of the second flame (the burner will run at low flame)

If the read temperature is less than working temperature set up minus the hysteresis value (3°C) = ON of the second flame (the burner will run at high flame)

Hysteresis on “SL” boiler high working temperature (burner ON/OFF)

Read temperature = temperature set point = burner OFF

If read temperature is less than temperature set point minus Hysteresis (fixed at °C) = Burner ON

THERMOSTATS

There are usually two: one for limiting or regulating; the other for safety or locking.

- The limiting thermostat shuts down the burner when it has reached the temperature: and automatically restarts it at a predetermined value; moreover, it provides for a contact to actuate the second flame of the two stage burner.
- The safety thermostat locks the burner at a fixed temperature value and sends out an alarm signal. Re-starting occurs only after the cause of the alarm has been removed and the system has be reset by operating the reset button on the switchboard.

IMIT Thermostat: The contact breaker has three screws C-1-2. The C-1 connection closes at a temperature lower than the minimum and up as far as maximum. The C-2 connection is switched on at a temperature exceeding the maximum. Gauging can be effected by operating the handle positioned on the thermostat box.

THERMOMETER (Fig. 6)

The stainless steel thermometer has a great dial, with a suitable full scale and 4000 mm capillary.

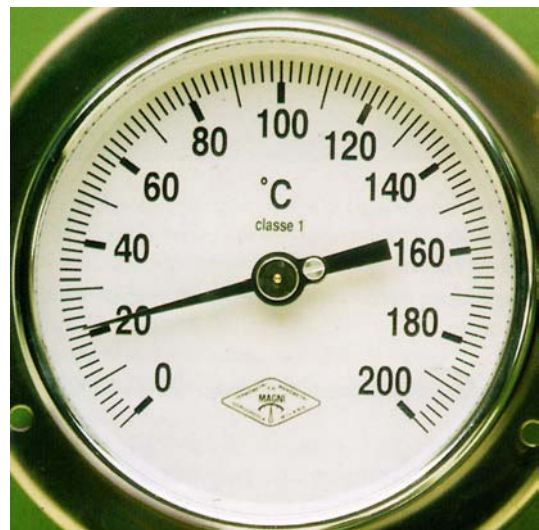

Fig. 6

3.4 ELECTRIC CONNECTIONS

The boilers are provided with a switchboard (protection level IP 55) completely assembled to the various boiler accessories.

Before connecting the switchboard, make sure that the electric system has been correctly installed, checking in particular the efficiency of the earthing system.

Wiring diagram

Refer to the diagram supplied with the specific switchboard.

3.5 SMOKESTACK

The connection from the boiler to the base of the smokestack must slope upwards in the direction of the gas flow, with a slope that should be at least 10%. The path should be as short and as possible and the bends and connections designed as to the rules used in the design of air ducts.

For lengths of up to 2 metres, the same diameter as the boiler flue gas outlet can be used (see the technical specification table). For more tortuous paths, the diameter must be suitable increased.

The smokestack must in any case be dimensioned as to applicable regulations. It is advisable to pay great attention to the inside diameter, insulation, gas tightness, ease of cleaning and to the fitting required for taking flue gas samples for combustion analysis.

3.6 BURNER

To better answer to user demand, it is advisable to install a **two-stage burner** or a **modulating burner**; this avoids large pressure variations consequent on sudden stream demands.

Further, and above all with natural gas, every burner start-up is preceded by a long period of preventionation of the combustion chamber, with consequent loss of heat to the smokestack.

BOILER - BURNER COUPLING

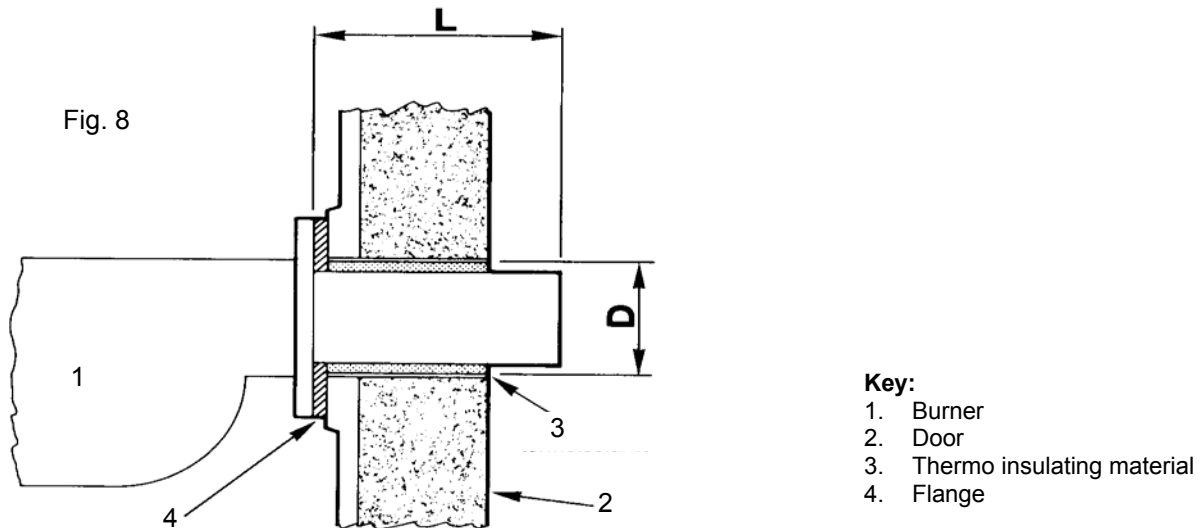

Verify that the spaces between the burner sleeve and the boiler door are suitable filled with flame-resistant ceramic insulation (Fig. 8).

4 STARTING

First check to see that the fastenings are completely locked and that the blank discs provided in the case of hydraulic testing are removed.

Now check that the water pipes are clean by repeated washing out into the sewer before final filling.

Check that the front and back hatches are correctly closed.

WARNING: During the first starting up it is very important to tighten progressively the two nuts of the small door, little by little as the pressure increases.

Otherwise a dangerous situation is created owing to the drawing which, once it has occurred, renders the packing useless in addition to being risky for the staff employed in the station.

5 MAINTENANCE

5.1 ORDINARY

- Periodically purge the level gauges, probe holder if fitted and the boiler, to avoid the accumulation of sludge.
- Check the efficiency of the control and regulation instruments, examining carefully the electrical parts (connections included) and the mechanical parts (pressure switches); it is advisable to replace every year the ceramic probe-holders.
- Carry out burner maintenance (as to the specific instructions);
- Check the tightness of flange bolts and the state of the gaskets;
- Check the conditions of the boiler door internal covering;
- Clean the flue-gas tube bundle and the turbolators
- Carry out correct maintenance to the pump (bearings, mechanical seal)
- Check for wear to the discharge valves; these tend to wear more quickly, due to the abrasive effect of the sludge during blow-down;

5.2 SCHEDULED

All boilers must be periodically stopped for careful inspection and maintenance: the time interval between stops is established by experience, by the operating conditions, by the quality of the feedwater and by the type of fuel used.

Before entering the boiler shell for inspection or for cleaning, check carefully that there is no possibility of entry of water via the pipework to which the boiler is connected. Every valve must be locked and if necessary isolated by removing a piece of pipework or by inserting a blind flange.

The parts under pressure must be carefully examined internally to identify any encrustation, **corrosion** and other potential **sources of danger linked to the feed water**.

All deposits must be removed mechanically or chemically and **the effective thickness of the structures must be verified using suitable instruments to determine that they are equal to or greater than the design values**. All pustules or other types of corrosion must be scraped and cleaned with a steel wire brush to white metal. Leaks between fire tubes and tube plates must be carefully examined: any welding must be done in all cases observing legal obligations, without forgetting that a boiler is a pressure vessel with danger of explosion and subject to control by competent authorities.

During inspection also verify all the accessories, with priority to safety valves, level probes and pressure switches.

5.3 CONSERVATION DURING WHEN OUT OF SERVICE

Often during periods of disuse the worst cases of corrosion appear. The operations to be carried out to guarantee correct conservation of the boiler depend essentially on the duration of the stop.

The boiler can be subjected to dry conservation if the period of disuse is long, or to a wet conservation for short stops or if the boiler has a back-up function and must be ready to come on-line in a short time.

In both cases, the necessary operations tend to eliminate the causes of possible corrosion.

DRY CONSERVATION

The boiler must be drained and dried carefully, then placing in the boiler shell a hygroscopic substance (for example lime or silica gel etc)

WET CONSERVATION

The boiler must be filled completely, given that corrosion is a phenomenon that appears due to the simultaneous presence of water and Oxygen. Therefore all traces of Oxygen must be removed from the water, also avoiding the successive infiltration of air. There are substances that absorb Oxygen, such as hydrazine and Sodium Sulphite, but after their use the water alkalinity must be checked.

6 WATER CHARACTERISTICS

For generators with heating surface over 15 sqm, **there are some regulations that require limit values for water characteristics**. These values are listed in the tables below.

However, limits should be adopted for all generators as stated by qualified companies that recommend the type of treatment to be carried out basing on careful analysis of the available water. **Many faults and sometimes serious accidents are caused by the use of water with non-conforming features.**

6.1 FEEDWATER - LIMIT VALUES (ENTERING THE BOILER)

Tab.1

Characteristics	Unit of measurement	Pressure ≤ 15 bar	Pressure ≤ 25 bar
pH		7 ÷ 9,5	7 ÷ 9,5
Total hardness	mg/l CaCO ₃	10	5
Oxygen (1)	mg/l O ₂	0,1	0,05
Free Carbon Dioxide (1)	mg/l CO ₂	0,2	0,2
Iron	mg/l Fe	0,1	0,1
Copper	mg/l Cu	0,1	0,1
Oily substances	mg/l	1	1
Aspect	Clear, limpid, no persistent foam.		

- (1) These values are valid to have a thermo degassing device. Without degassing device, the temperature of the tank water must be increased to at least 80 Celsius (see chapter 2.3. - Feeding) to reduce the content of dissolved gasses (O₂ and CO₂). Chemical deoxygenators must be used to remove completely the oxygen from the feed water and reduce as much as possible CO₂ corrosive effects.

6.2 BOILER WATER - LIMITING VALUES

Tab.2

Characteristics	Unit of measurement	Pressure ≤ 15 bar	Pressure ≤ 25 bar
pH		9 ÷ 11	9 ÷ 11
Total alkalinity	mg/l CaCO ₃	1000	750
Total hardness	mg/l CaCO ₃	10	5
Maximum conductivity (4)	μS/cm	8000	7000
Silica	mg/l SiO ₂	150	100
STD (4)	mg/l	3500	3000
Conditioner (2)			
Aspect	Clear, limpid, no persistent foam		

(1) To maintain in the boiler the parameters of alkalinity and silica within the prescribed or recommended limits, the boiler must be purged, if possible continuously. The values of the concentrations in the feedwater and in the boiler water are linked to the continuous purge by the following relationship:

$$S\% = 100 \frac{Ca}{Cc}$$

where

- S% = Percentage of purge with respect to the feed water supplied to the boiler;
- Ca = Real concentration of a certain salt or ion in the feed water
- Cc = Maximum allowed concentration in the boiler for the same salt.

- (2) Correct management presupposes normally the use of conditioners, whose dosages and limits are in relation to the nature and characteristics of the additives themselves.
- (3) Determined on a filtered sample
- (4) The two parameters have the same physical meaning but the values can be correlated only if the chemical composition of the water is known.

6.3 FREQUENCY OF THE ANALYSES

The frequency of analysis is determined evidently as a function of the use of the boiler and of the quality of the water used; it is advisable in any case to check the pH, the total hardness and the alkalinity of the feed and boiler waters at least every two days. Once a month, especially under conditions of variable operation, it is advisable to subject meaningful samples of the boiler and feed waters to complete analysis.

7 FAULTY OPERATION

FAULT	PROBABLE CAUSE	SUGGESTED REMEDY
Safety valve/s opening	Maximum pressure exceeded, as set on the valve. Must be equal to the boiler design pressure.	Adjust the safety pressure switches and / or limit switches.
	Loss of the adjustment of the safety valve	Check and then adjust the valve using a reference gauge
Small leaks from the safety valve/s	Dirt on the valve seat	Clean the seat by opening the valve manually a few times
	Marks on the valve seat	Dismantle the valve and regrind the valve seat with very fine abrasive.
Pressure safety switch operates	Pressure limit switch set too high	Adjust the pressure limit switch
	Pressure limit switch faulty	Replace the pressure limit switch
	Pressure switch pipe coil blocked	Clean or replace the pipe coil
Burner always ON	Erroneous electrical connection to the panel	Consult the wiring diagram
	Control and/or safety pressure switches inactive	Check the adjustment of the pressure switches
		Check the pressure switch connections to the control panel
Burner always OFF	Problems with the burner	See the specific burner Manual
	Burner fuses interrupted	Replace the fuses
	No consent to the burner from the control thermostat	Replace the control thermostat
	Erroneous connection to the control panel	Consult the wiring diagram



Via G. Pascoli, 38 (S.S. 434 - km 9) S. Maria di Zevio - VERONA - ITALIA
Tel. 045/8738511 - Fax 045/8731148
info@icicaldaie.it - www.icicaldaie.com

The data reported are indicative only and are not binding. Our company reserves the right to introduce alterations at any time as it deems fit and proper for the development of the product.