

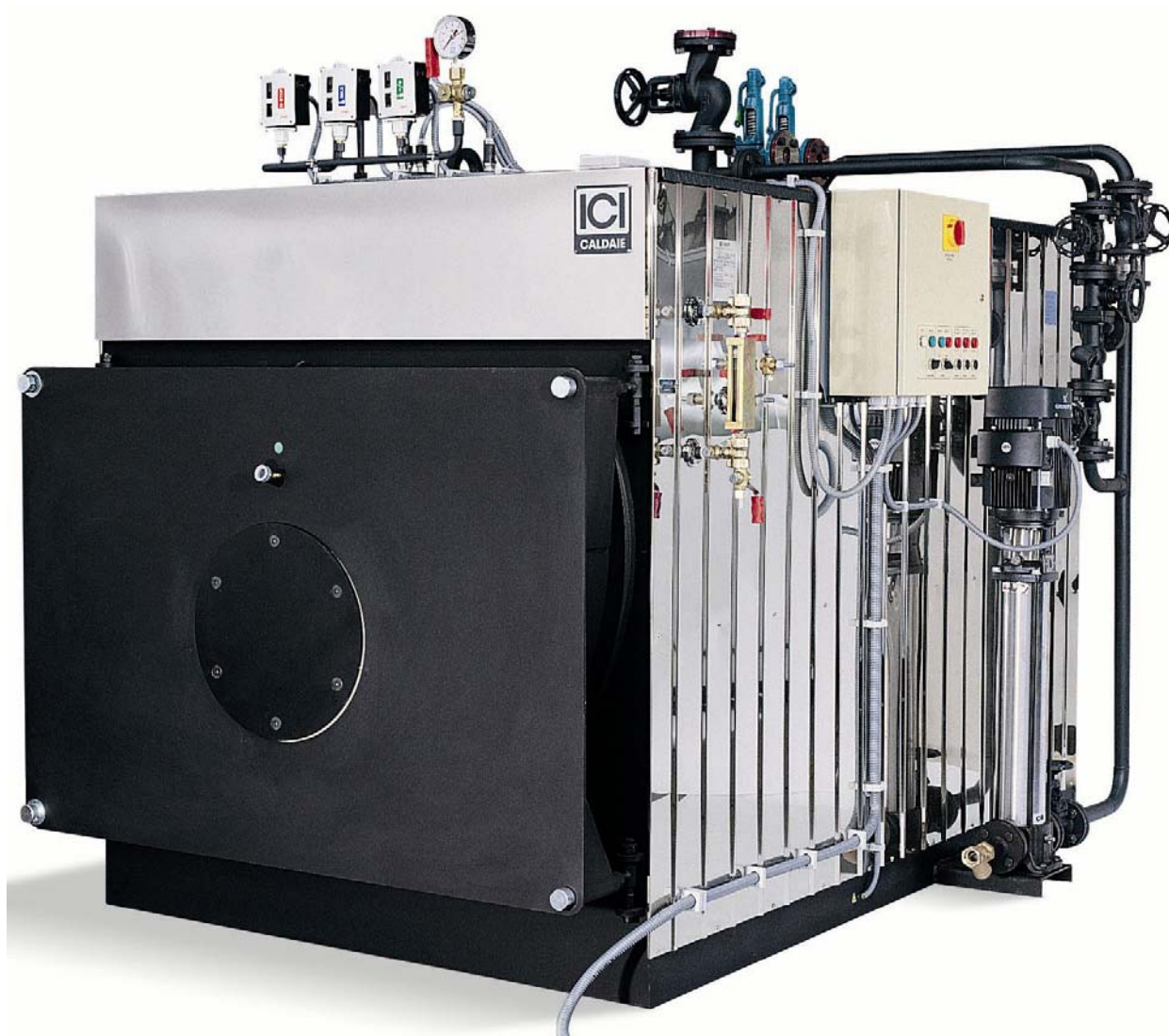

TECHNICAL MANUAL

GB



AX

STEAM GENERATOR

INDEX

1	TECHNICAL CHARACTERISTICS	2
1.1	GENERAL	2
1.2	CHARACTERISTICS	2
1.3	TECHNICAL DATA	3
2	ACCESSORIES	4
2.1	PRESSURE	4
2.1.1	Pressure gauge (Fig. 2)	4
2.1.2	Operation pressure switch	5
2.1.3	Safety pressure switch	5
2.1.4	Safety valves	6
2.2	LEVEL	6
2.2.1	Level indicator gauge	6
2.2.2	Automatic level regulator and water level limits (Fig. 7)	7
2.3	FEED WATER	7
2.3.1	Injector	8
3	INSTALLATION	9
3.1	SITING	9
3.2	WATER CONNECTIONS	9
3.3	ELECTRIC CONNECTIONS	10
3.4	SMOKESTACK	10
3.5	BURNER	10
3.5.1	Boiler - Burner coupling	10
4	BOILER OPERATION	11
4.1	FIRST START-UP	11
4.2	NORMAL OPERATION	11
5	MAINTENANCE	12
5.1	ORDINARY	12
5.2	PERIODIC	12
5.2.1	Periodic control (every 6 hours of use)	12
5.3	SCHEDULED	14
5.4	CONSERVATION DURING WHEN OUT OF SERVICE	14
5.4.1	Dry conservation	14
5.4.2	Wet conservation	14
6	WATER CHARACTERISTICS	15
6.1	FEEDWATER - LIMIT VALUES (entering the boiler)	15
6.2	OPERATING WATER - LIMITING VALUES	15
6.3	FREQUENCY OF THE ANALYSES	15
7	TROUBLESHOOTING	16
8	WATER LEVEL LIMITS	17
8.1	GENERAL	17
8.2	TYPICAL APPLICATIONS	18
8.3	ELECTRICAL CONNECTIONS	18
8.4	STEAM GENERATOR OPERATION	19
8.5	FIRST START-UP	19
8.6	MAINTENANCE	19
8.6.1	Ordinary	19
8.6.2	Periodic control (every 6 hours of use)	19
8.6.3	Extraordinary maintenance (water level limits substitution)	21
8.7	TROUBLESHOOTING	21
8.8	DATA LABEL	22

1 TECHNICAL CHARACTERISTICS

1.1 GENERAL

The AX series steam boilers are type semi-fixed, horizontal smoke-tube type, complete with accessories. The boilers are suitable for operation with pressurised burners for gas, fuel oil or heavy oil. Safety, reliability, high efficiency and high quality saturated steam are the characteristics of our boilers. Please consult the instructions with attention.

This high-pressure steam (12-15 kgf/cm²) generator uses a combustion chamber with flue gas inversion. For operation at up to 3000 kg/h of steam generated there is partial exoneration (in Italy) in the employment of specialist boiler operators. Local requirements as to personnel qualification MUST be taken into account for the country where the unit is installed.

1.2 CHARACTERISTICS

- **Working pressure switches** for operation (controlling the 1st and 2nd burner flame).
- **Locking pressure switches** (stops the burner on reaching the maximum steam pressure; the boiler is manually reset from the control panel).
- **Automatic level regulator** (2 probes connected to an electronic conductivity relay maintain the water level between the set levels).
- **Water level limits** (2 probes connected to two independent electronic conductivity relays stop the burner if the water level falls below the safe minimum; reset is manual on the control panel).

TECHNICAL CHARACTERISTICS

1.3 TECHNICAL DATA

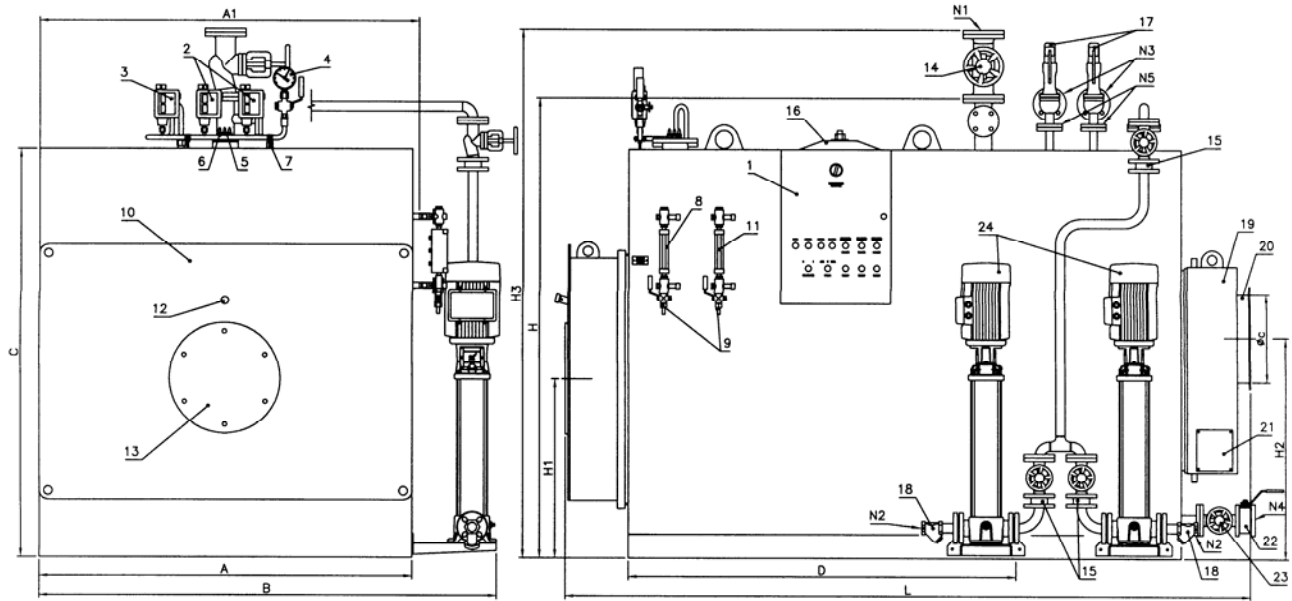

Fig. 1

LEGEND

- | | | | |
|----|------------------------------------|----|-----------------------|
| 1 | Switchboard | 16 | Inspection door |
| 2 | Control pressure switches | 17 | Safety valves |
| 3 | Safety pressure switch | 18 | Feed filter |
| 4 | Pressure gauge | 19 | Back smokebox |
| 5 | 1 st safety level probe | 20 | Smokestack connection |
| 6 | Level control probes | 21 | Cleaning door |
| 7 | 2 nd safety level probe | 22 | Rapid exhaust valve |
| 8 | 1 st level gauge | 23 | Exhaust valve |
| 9 | Level gauge drain | 24 | Feed pumps |
| 10 | Front plate | | |
| 11 | 2 nd level gauge | N1 | Steam intake |
| 12 | Flame inspection hole | N2 | Feed |
| 13 | Burner plate | N3 | Safety valves exhaust |
| 14 | Steam take-off | N4 | Boiler exhaust |
| 15 | Non return valve | N5 | Safety valves fitting |

Model	Heat output		Steam * capacity kg/h	Counte r press. mbar	Size mm										Fittings DN/in					Weight ** kg	
	kcal/h	kW			A	A1	B	C	D	H	H1	H2	H3	L	Øc	N1	N2	N3	N4		N5
AX 200 ⁽⁴⁾	200.000	233	340	3,5	1080	1130	1480	1240	1520	1420	575	720	1600	2100	250	32	1 ¹ / ₄	40	32	25	1500
AX 300 ⁽⁴⁾	300.000	349	510	3,5	1240	1290	1640	1400	1520	1600	640	815	1780	2100	250	32	1 ¹ / ₄	40	32	25	1800
AX 400 ⁽⁴⁾	400.000	465	680	5,0	1240	1290	1640	1400	1770	1600	640	815	1800	2350	250	40	1 ¹ / ₄	40	32	25	2100
AX 500 ⁽⁴⁾	500.000	581	850	4,5	1400	1450	1800	1560	1770	1780	700	900	1980	2450	300	40	1 ¹ / ₄	40	32	25	2600
AX 600 ⁽⁴⁾	600.000	698	1020	6,0	1400	1450	1800	1560	2020	1780	700	900	2010	2700	300	50	1 ¹ / ₄	40	32	25	3000
AX 800 ⁽⁴⁾	800.000	930	1370	5,5	1550	1600	1950	1710	2020	1930	735	950	2160	2700	350	50	1 ¹ / ₄	40	32	25	3600
AX 1000 ⁽⁴⁾	1.000.000	1163	1700	7,0	1550	1600	1950	1710	2320	1930	735	950	2220	3000	350	65	1 ¹ / ₄	40	32	25	4300
AX 1200 ⁽⁴⁾	1.200.000	1395	2040	8,0	1680	1730	2100	1850	2520	2080	810	1000	2370	3200	400	65	1 ¹ / ₄	40	32	25	4900
AX 1500 ⁽⁴⁾	1.500.000	1744	2560	6,5	1840	1890	2260	1990	2720	2240	850	1080	2550	3450	450	80	1 ¹ / ₄	40	32	25	6800
AX 1750 ⁽⁴⁾	1.750.000	2035	3000	7,5	1840	1890	2260	1990	3020	2240	850	1080	2550	3750	450	80	1 ¹ / ₄	50	32	32	7500
AX 2000	2.000.000	2326	3400	8,0	1950	2000	2450	2150	3030	2400	880	1240	2710	3800	500	80	1 ¹ / ₄	50	32	32	8500
AX 2500	2.500.000	2907	4270	9,0	2100	2150	2600	2300	3530	2550	950	1240	2900	4350	550	100	40	50	40	32	10000
AX 3000	3.000.000	3488	5100	9,5	2200	2250	2700	2400	3780	2650	970	1300	3000	4650	600	100	40	65	40	40	11300

* 80°C feeding water
 ** Data referred to 12 bar.

2 ACCESSORIES

AX steam boilers are fitted with a series of accessories that can be subdivided as follows:

- Safety accessories (safety valves, water level limits, safety pressure switches).
- Observation accessories (level gauge, pressure gauge, flame inspection).
- Control accessories (level and pressure switches).
- Feed water accessories (centrifugal pump, injector or alternating steam pump).
- Manual operation accessories (stop valves, purge valve).

In the following description the accessories are subdivided as to the physical parameter they control (pressure and level).

2.1 PRESSURE

2.1.1 Pressure gauge (Fig. 2)

The pressure gauge is Bourdon type consisting of a flat elliptical section metal tube, bent to an arc. One end of the tube is open and communicates with the boiler where the pressure is to be measured; the other end, closed and free to move is connected by a lever system to a toothed arc and to the gauge indicator hand.

The gauge shows in red the design pressure.

The gauge is carried on a three-way valve to allow the following operations:

- Communication between boiler and gauge (normal operation position).
- Communication between gauge and the atmosphere (position necessary to purge the siphon).
- Communication between the boiler, the gauge and a test gauge (position necessary to verify the gauge).

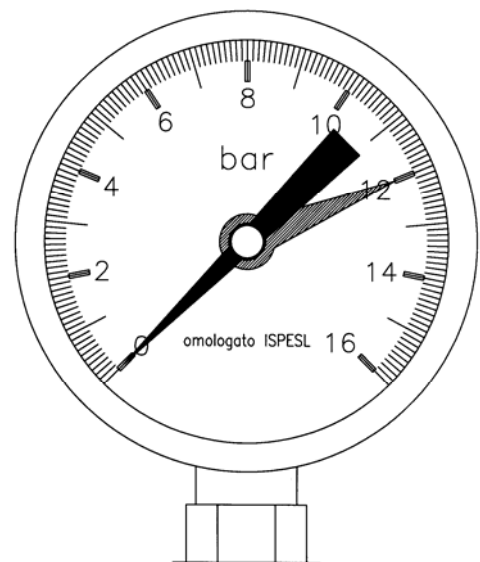

Fig. 2

2.1.4 Safety valves

These valves have the function of discharging steam when the maximum design pressure of the boiler is reached.

The valves used on boilers can be of the type **Lever and weight** (Fig. 5) or **Spring** (Fig. 6).

The boiler operator must pay much attention to the safety valves and carry out careful and diligent maintenance. The safety valve is the most important and sensitive accessory on the boiler and represents the best guarantee that the internal pressure of the boiler does not exceed the design pressure.

As during normal operation of a boiler, the safety valve never acts, it is **good practice to check that the valve is free, i.e. that the valve plug is not stuck to the seat**, by acting on the side lever (spring valves) or on the horizontal lever carrying the weight (lever and weight valves) until the valve starts to discharge steam.

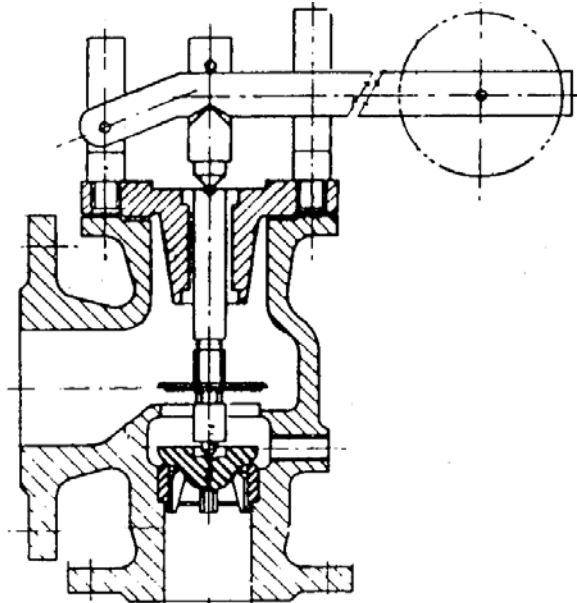

Fig. 5

WARNING

On first start-up, you must verify that safety valve adjustment is made to the boiler design pressure.

Generally the spring safety valve is supplied already adjusted, while the lever and weight type must be adjusted by moving the weight along the lever until the opening pressure value corresponds to the boiler design pressure.

The safety valve installed on steam boilers must have the discharge piped to outside the boiler room. Particular care must be taken in designing the discharge line; we show some here.

- The discharge line should be of diameter at least equal to that of the discharge flange on the safety valve.
- Only wide radius curves must be used in the discharge line.
- The entire discharge line must be built to avoid the formation of condensation locks. There must be therefore adequate slopes to ensure complete drainage.

Particular care must be taken if the valve seat and plug are to be ground; if this operation becomes necessary due to leaks, use abrasives based on silicon carbide or oil based carborundum. Carry out the first grinding operation using fine grain abrasive, finishing with a very fine grain abrasive.

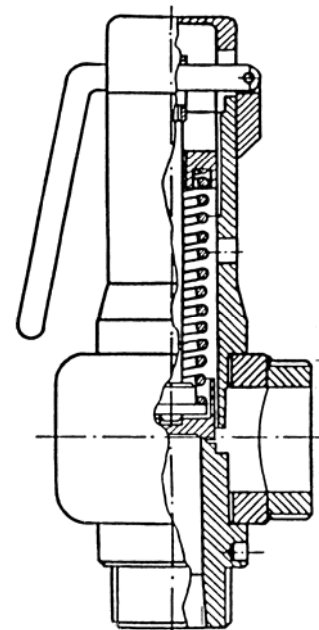

Fig. 6

2.2 LEVEL

2.2.1 Level indicator gauge

The level indicator consists of a pair of valves connected to a sight glass box containing a prismatic glass. This device is connected to the boiler both above and below the normal water level, while the lower part is fitted with a purge valve so that any sludge can be removed, to keep the glass clean. Using these valves, the efficiency of the level control system can be verified periodically by carrying out the following operations:

- Open for a few seconds and then close the purge valve. If the water disappears from the sight glass and then appears again with ample level oscillation, then it can be considered that the level operates correctly. If on the other hand the water returns slowly or stops at a level differing from the preceding level, then one of the communications may be obstructed. To make sure which of the two is obstructed, and to attempt a purge, close the steam valve leaving the water valve open, then open the purge valve. This valve must release water taking with it any sludge formed in the pipes. Then close the water valve and open the steam valve: steam should be released from the purge valve. Closing the purge valve and leaving the two water and steam valves open, the water should return to the initial level. If this does not occur, the communication pipes between the level and the boiler must be cleaned.

ACCESSORIES

2.2.2 Automatic level regulator and water level limits (Fig. 7)

The physical principle employed to detect and control the water level is based on the electrical conductivity of the water. The control device consists of a part sited in the control panel (electronic relays) and of probes of differing lengths immersed in the boiler shell.

Operation of the system provides for:

- **Automatic pump start and stop:** Two probes inserted in the boiler, of which the longer starts, and the shorter stops the pump, connected to a single control relay in the control panel.
- **Burner stop at low water level:** two probes of the same length, inserted in the boiler and connected to two distinct control relays in the control panel, stop the burner permanently if the water level drops below the admissible level.

Boiler probes:

- 6 Pump stop
- 7 Pump start
- 8 1st safety burner stop and alarm on.
- 9 2nd safety burner stop and alarm on.

N.B.: we suggest that as well as the acoustic alarm in the boiler room, a further acoustic alarm be provided in an area where personnel is normally present.

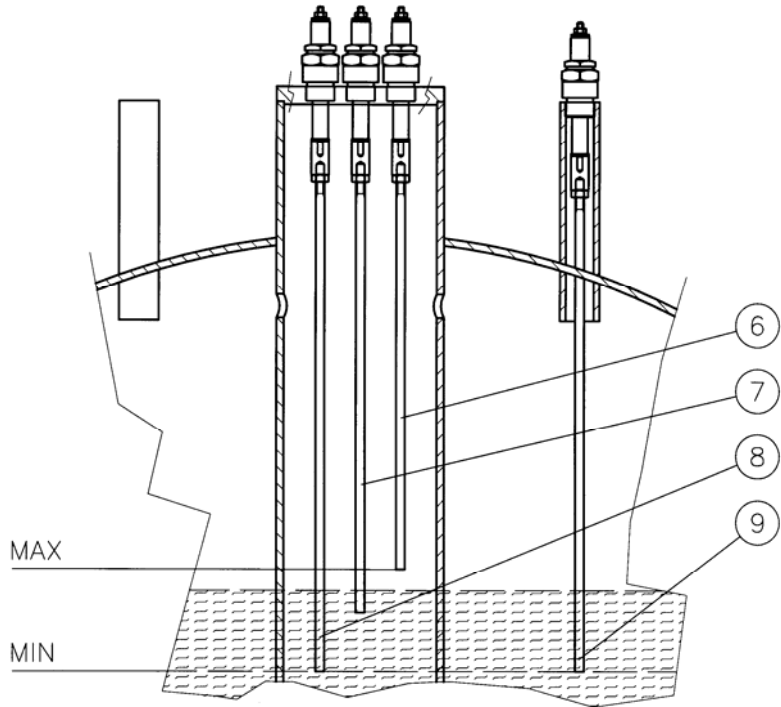

Fig. 7

2.3 FEED WATER

An electric centrifugal pump supplies the water. The inlet side of the pump must never be under suction pressure, but always under positive pressure due to the difference in height between the pump itself and the feed water tank. While a pump can operate under suction head from a cold water tank (up to 5-6 m), if the water is hot the pump cannot operate and indeed needs the water to be delivered under a certain pressure. The height of the feed water tank varies with the temperature, as shown in the following table:

Feed water temperature (Celsius)	Positive water head (metres)
60	1
70	2
80	3
90	4,5

WARNING

- Avoid the use of feed water at temperatures lower than 60 Celsius, being rich in Oxygen and therefore such as to cause corrosion.
- To avoid pump cavitation problems, the feed water temperature should not be higher than 90 Celsius.

2.3.1 Injector

The injector operates with steam from the boiler, transforming its kinetic energy (arising from flow rate) into pressure, which is then able to direct feed water into the boiler itself.

Fig. 8 illustrates the two convergent cones, (C^1) and (C^2), in which the steam passes at a progressively increasing speed, adjusted on taper valve (VC) which is operated by unit (M) and cam (E). Because of its high flow rate, the steam creates a vacuum in the chamber between cones (C^1) and (C^2). This vacuum sucks the water from the feed tank so that it mixes with the steam, which then largely condensates, after which the water-steam mixture passes into divergent cone (C^3), where it loses speed but retains pressure.

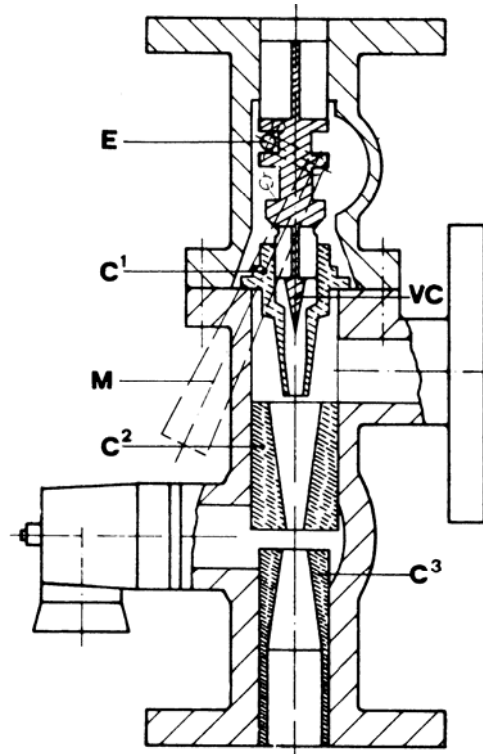

Fig. 8

The system can operate up to the maximum pressure of 15 kgf/cm^2 on intake at a maximum feed water temperature of 40°C .

It must be avoided to suck water from the condensate tank because it has water at a very high temperature.

In order to connect the injector, it is good practice to ensure that all the steam and water pipes, as well as related cocks and valves, provide an internal throughput similar to that of the injector fittings.

Operating procedures are as follows:

- Having opened the steam valve, slowly operate the lever, moving it towards an intermediate position until water appears out of the discharge.
- Continue this operations slowly until the lever has completed a rotation of 90° and at least until the injector begins intake. Correct operation is accompanied by a typical whistling sound.
- To halt operation, return the lever into its start position and then close the steam valve.

3 INSTALLATION

3.1 SITING

Our steam boilers are supplied as units and do not need any foundation work. A flat even floor only is needed, that can be raised by 5-10 cm.

3.2 WATER CONNECTIONS

The steam boilers once positioned are connected to the system as follows (Fig. 9):

Water

From the condensate collection tank (10) (if existing; otherwise from the treated water tank) to the suction side of the feed water pump (9).

Steam

From the main steam take-off valve (3) to the user services (distributor or others), from the safety valve outlets (6) to outside the boiler room in a safe position.

Drains

From the level indicator drains (16), the boiler drain (17) to the drainage network.

Fuel

Connection to the burner foreseen for fuel oil or natural gas.

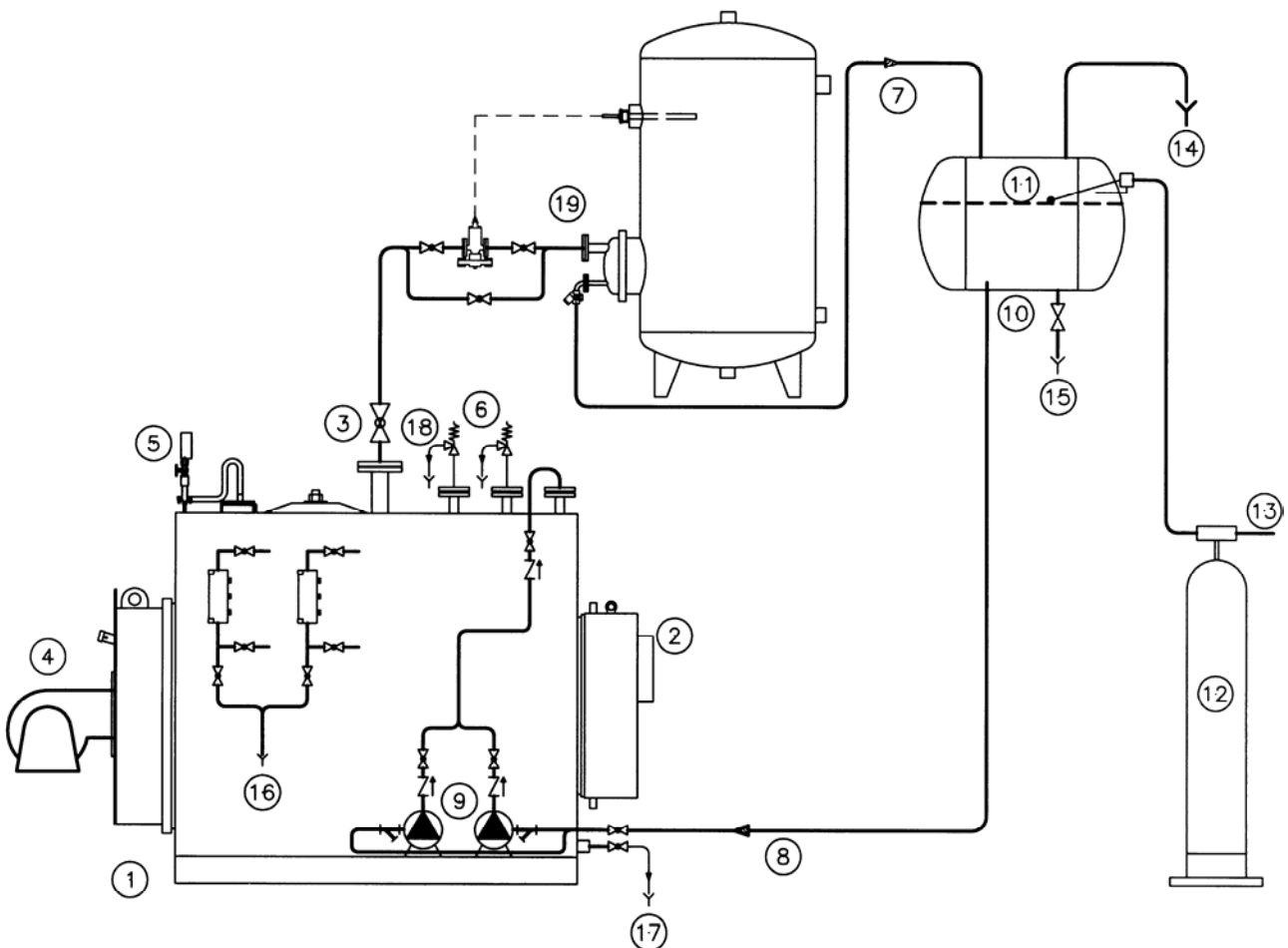

Fig. 9 – System diagram

LEGEND

- | | |
|--|---|
| <ul style="list-style-type: none"> 1. Boiler 2. Smokestack 3. Steam take-off 4. Burner 5. Pressure switches 6. Safety valves 7. Condensate return 8. Electric pump supply 9. Feed water pumps | <ul style="list-style-type: none"> 10. Condensate collection tank 11. Water level 12. Water treatment 13. Water supply 14. Breather 15. Condensate tank drain 16. Level indicator drain 17. Boiler drain 18. Safety valve drain 19. Example of user service |
|--|---|

INSTALLATION

3.3 ELECTRIC CONNECTIONS

The boilers are provided with a switchboard (protection level IP 55) completely assembled to the various boiler accessories. Before connecting the switchboard, make sure that the electric system has been correctly installed, checking in particular the efficiency of the earthing system.

Wiring diagram

Refer to the diagram supplied with the specific switchboard.

3.4 SMOKESTACK

The connection from the boiler to the base of the smokestack must slope upwards in the direction of the gas flow, with a slope that should be at least 10%. The path should be as short and as possible and the bends and connections designed as to the rules used in the design of air ducts.

For lengths of up to 2 metres, the same diameter as the boiler flue gas outlet can be used (see the technical specification table). For more tortuous paths, the diameter must be suitably increased.

The smokestack must in any case be dimensioned as to applicable regulations. It is advisable to pay great attention to the inside diameter, insulation, gas tightness, ease of cleaning and to the fitting required for taking flue gas samples for combustion analysis.

3.5 BURNER

To better answer to steam demand, it is advisable to install a **two-stage burner** or a **modulating burner**; this avoids large pressure variations consequent on sudden steam demands.

Further, and above all with natural gas, every burner start-up is preceded by a long period of pre-ventilation of the combustion chamber, with consequent loss of heat to the smokestack.

3.5.1 Boiler - Burner coupling

Verify that the spaces between the burner sleeve and the boiler door are suitably filled with flame-resistant ceramic insulation (Fig. 10).

The table shows the dimensions of the burner sleeves used on these steam boilers.

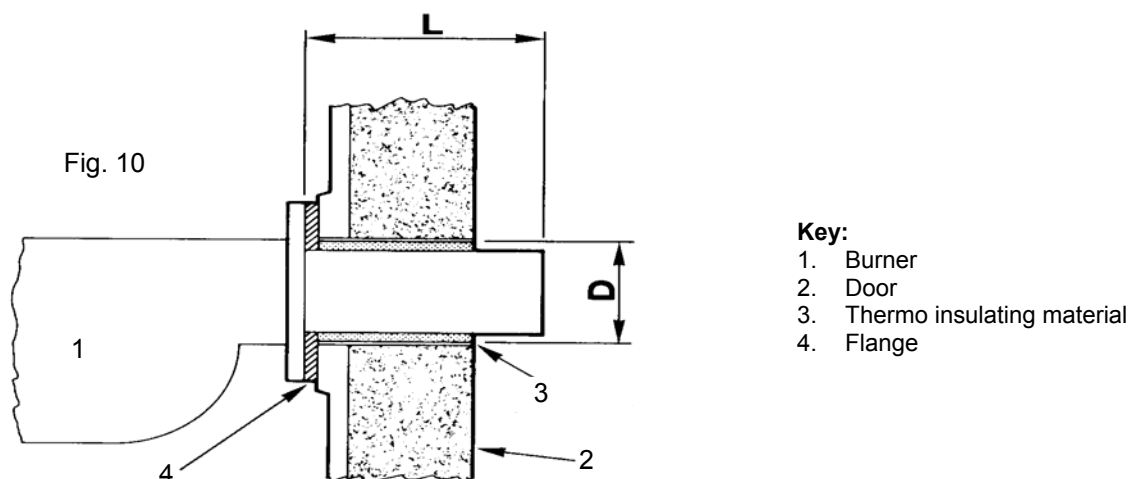

Boiler Type	L - Length of burner sleeve (mm)	D - Burner sleeve insertion hole (mm)
AX 200	280 ÷ 330	180
AX 300 ÷ 400	310 ÷ 360	225
AX 500 ÷ 600	350 ÷ 400	280
AX 800 ÷ 1000	370 ÷ 420	280
AX 1200	370 ÷ 420	320
AX 1500 ÷ 1750	420 ÷ 470	360
AX 2000	480 ÷ 530	360
AX 2500 ÷ 3000	480 ÷ 530	400

4 BOILER OPERATION

4.1 FIRST START-UP

WARNING: Before start up insert all the turbolators into the smoke tubes ensuring that there is a space of at least 100 mm at the front after they have been pushed fully inside.

- Verify that all fittings are tight.
- Verify that the feed water pipes are clean, carrying out a series of washing operations with drainage to waste before final boiler filling.
- Close the drain valves, the steam take-off valve and the level drains.
- Open the level control valves and the feed water valve (upstream of the feed water pump).
- Check that the upper man-way is correctly closed.
- Start the boiler as follows:
 - 1) Switch on the control panel by turning the main switch.
 - 2) Check that the drive shaft of the feed water pump is free to turn. By starting the pump manually for an instant, check that the shaft turns in the correct direction.
 - 3) Set the pump switch to AUT and verify that burner cannot start before the attainment of the minimum level;
 - 4) Check that the pump stops when the maximum level is reached by observing the level indicators and checking the positions of the indicator valves.
 - 5) Press and keep pressed the safety water level reset button for at least 10 seconds, the conductivity relay being of the delayed type.
 - 6) Open the boiler drain and check on the level indicator at what level the pump-start probe acts.
 - 7) Set the pump switch to "0" leaving the drain open and check the actuation level of the safety probes with respect to the minimum level reference plate.
 - 8) Close the drain and set the pump switch to AUT
 - 9) Switch on the burner and bring the boiler up to pressure adjusting the operation pressure.

WARNING: On boilers with a man-way, during the first start-up it is important to tighten progressively the nuts on the man-way cover as the pressure increase. Otherwise a hazardous situation is created due to steam leaks that quickly deteriorate the gasket creating a dangerous situation for the boiler room personnel.

4.2 NORMAL OPERATION

With cold start-ups, verify that:

- The boiler is full of water to the minimum level;
- The increase of the water volume due to heating does not raise the water level too far: if necessary drain the boiler at regular intervals to bring the visible level back to the centre of the water level sight glasses;
- On reaching the set pressure, the steam take-off valve can be opened very gradually in order to heat the steam delivery lines eliminating any condensate that may be present in the pipework;
- The man-way gasket does not leak.

5 MAINTENANCE

5.1 ORDINARY

- Periodically purge the level gauges, probe holder if fitted and the boiler, to avoid the accumulation of sludge;
- Check the efficiency of the control and regulation instruments, examining carefully the electrical parts (connections included) and the mechanical parts (pressure switches); it is advisable to replace every year the ceramic probe-holders;
- Carry out burner maintenance (as to the specific instructions);
- Check the tightness of flange bolts and the state of the gaskets;
- Check the conditions of the boiler door internal covering;
- Clean the flue-gas tube bundle and the turbolators;
- Carry out correct maintenance to the pump (bearings, mechanical seal),
- Check for wear to the discharge valves; these tend to wear more quickly, due to the abrasive effect of the sludge during blow-down.

5.2 PERIODIC

5.2.1 Periodic control (every 6 hours of use)

From time to time (every 6 hours of use) the thermal plant must be inspected by qualified personnel to check the efficiency of all safety accessories:

- Safety pressure switch
- Water level limits

The system can be reset if no anomalies have been encountered: power off the panel for approx. 20 seconds, power on the main switch and press the reset buttons.

For further details follow the flow chart below:

MAINTENANCE

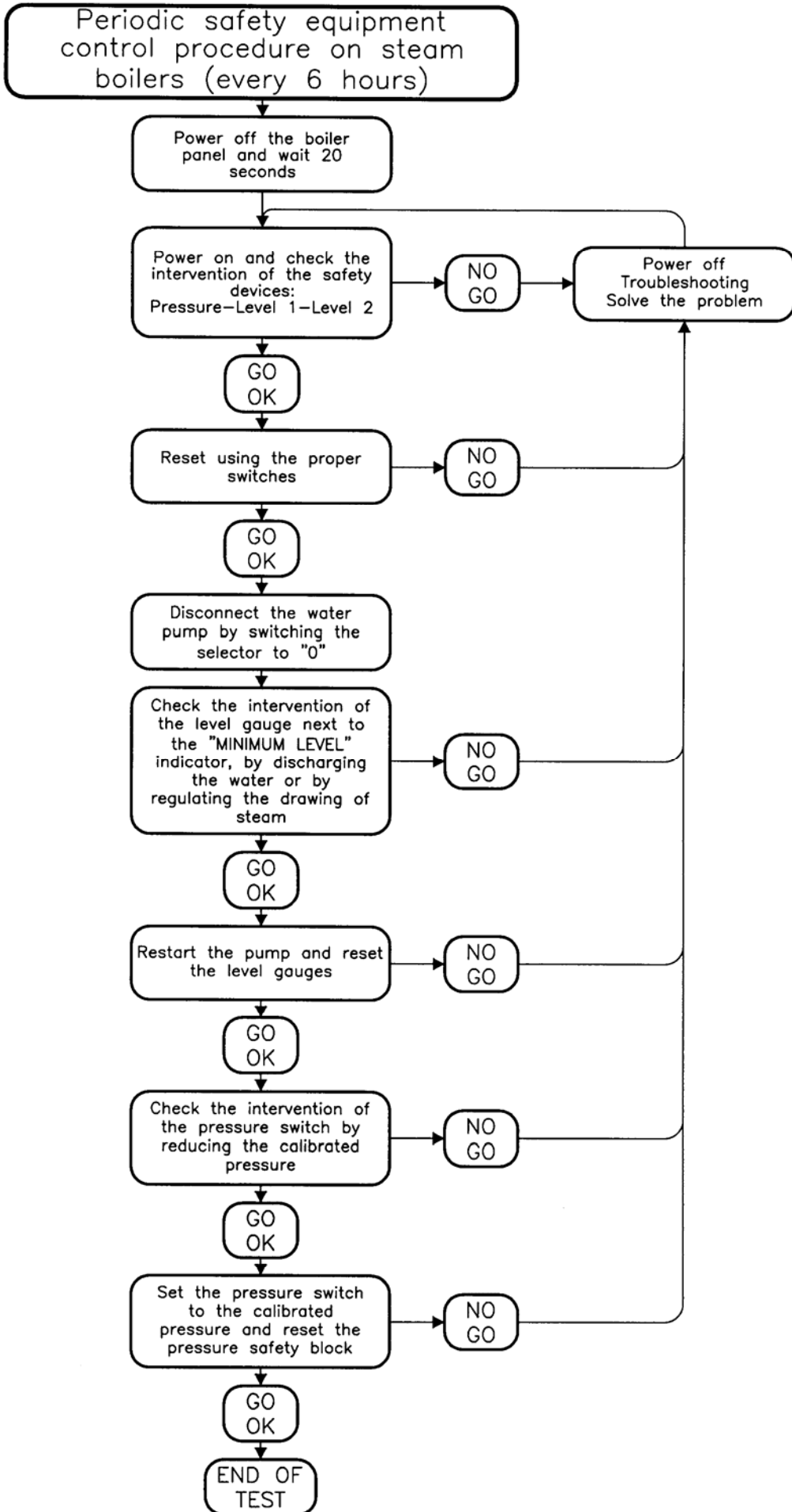

5.3 SCHEDULED

All boilers must be periodically stopped for careful inspection and maintenance: the time interval between stops is established by experience, by the operating conditions, by the quality of the feed water and by the type of fuel used.

Before entering the boiler shell for inspection or for cleaning, check carefully that there is no possibility of entry of water or steam via the pipework to which the boiler is connected. Every valve must be locked and if necessary isolated by removing a piece of pipework or by inserting a blind flange.

The parts under pressure must be carefully examined internally to identify any encrustation, **corrosion** and other potential **sources of danger linked to the feed water**.

All deposits must be removed mechanically or chemically and **the effective thickness of the structures must be verified using suitable instruments to determine that they are equal to or greater than the design values**. All pustules or other types of corrosion must be scraped and cleaned with a steel wire brush to white metal. Leaks between fire tubes and tube plates must be carefully examined: any welding must be done in all cases observing legal obligations, without forgetting that a steam boiler is a pressure vessel with danger of explosion and subject to control by competent authorities.

During inspection also verify all the accessories, with priority to safety valves, level probes and pressure switches.

5.4 CONSERVATION DURING WHEN OUT OF SERVICE

Often during periods of disuse the worst cases of corrosion appear. The operations to be carried out to guarantee correct conservation of the boiler depend essentially on the duration of the stop.

The boiler can be subjected to dry conservation if the period of disuse is long, or to a wet conservation for short stops or if the boiler has a back-up function and must be ready to come on-line in a short time.

In both cases, the necessary operations tend to eliminate the causes of possible corrosion.

5.4.1 Dry conservation

The boiler must be drained and dried carefully, then placing in the boiler shell a hygroscopic substance (for example lime or silica gel etc)

5.4.2 Wet conservation

The boiler must be filled completely, given that corrosion is a phenomenon that appears due to the simultaneous presence of water and Oxygen. Therefore all traces of Oxygen must be removed from the water, also avoiding the successive infiltration of air. There are substances that absorb Oxygen, such as hydrazine and Sodium Sulphite, but after their use the water alkalinity must be checked.

6 WATER CHARACTERISTICS

For steam generators with heating surface over 15 sqm, **there are some regulations that require limit values for water characteristics.** These values are listed in the tables below.

However, limits should be adopted for all generators as stated by qualified companies that recommend the type of treatment to be carried out basing on careful analysis of the available water. **Many faults and sometimes serious accidents are caused by the use of water with non-conforming features.**

6.1 FEEDWATER - LIMIT VALUES (entering the boiler)

Tab.1

Characteristics	Unit of measurement	Pressure ≤ 15 bar	Pressure ≤ 25 bar
pH		7 ÷ 9,5	7 ÷ 9,5
Total hardness	mg/l CaCO ₃	10	5
Oxygen (1)	mg/l O ₂	0,1	0,05
Free Carbon Dioxide (1)	mg/l CO ₂	0,2	0.2
Iron	mg/l Fe	0,1	0,1
Copper	mg/l Cu	0,1	0.1
Oily substances	mg/l	1	1
Aspect	Clear, limpid, no persistent foam.		

(1) These values are valid to have a thermo degassing device. Without degassing device, the temperature of the tank water must be increased to at least 80 Celsius (see chapter 2.3. - Feeding) to reduce the content of dissolved gasses (O₂ and CO₂). Chemical deoxygenators must be used to remove completely the oxygen from the feed water and reduce as much as possible CO₂ corrosive effects.

6.2 OPERATING WATER - LIMITING VALUES

Tab.2

Characteristics	Unit of measurement	Pressure ≤ 15 bar	Pressure ≤ 25 bar
pH		9 ÷ 11	9 ÷ 11
Total alkalinity	mg/l CaCO ₃	1000	750
Total hardness	mg/l CaCO ₃	10	5
Maximum conductivity (4)	μS/cm	8000	7000
Silica	mg/l SiO ₂	150	100
STD (4)	mg/l	3500	3000
Conditioner (2)			
Aspect	Clear, limpid, no persistent foam		

(1) To maintain in the boiler the parameters of alkalinity and silica within the prescribed or recommended limits, the boiler must be purged, if possible continuously. The values of the concentrations in the feedwater and in the boiler water are linked to the continuous purge by the following relationship:

$$S\% = 100 \frac{Ca}{Cc}$$

Where

S% = Percentage of purge with respect to the feed water supplied to the boiler;

Ca = Real concentration of a certain salt or ion in the feed water

Cc = Maximum allowed concentration in the boiler for the same salt.

(2) Correct management presupposes normally the use of conditioners, whose dosages and limits are in relation to the nature and characteristics of the additives themselves.

(3) Determined on a filtered sample

(4) The two parameters have the same physical meaning but the values can be correlated only if the chemical composition of the water is known.

6.3 FREQUENCY OF THE ANALYSES

The frequency of analysis is determined evidently as a function of the use of the boiler and of the quality of the water used; it is advisable in any case to check the pH, the total hardness and the alkalinity of the feed and boiler waters at least every two days. Once a month, especially under conditions of variable operation, it is advisable to subject meaningful samples of the boiler and feed waters to complete analysis.

It is also advisable to inspect the return condensate for traces of any highly contaminating oily substances (reduction of evaporation from the water surface in the boiler caused by a layer of oil).

TROUBLESHOOTING

7 TROUBLESHOOTING

FAULT	PROBABLE CAUSE	SUGGESTED REMEDY	
Safety valve/s opening	Maximum pressure exceeded, as set on the valve. Must be equal to the boiler design pressure.	Adjust the safety pressure switches and / or limit switches.	
	Loss of the adjustment of the safety valve	Check and then adjust the valve using a reference gauge	
Small leaks from the safety valve/s	Dirt on the valve seat	Clean the seat by opening the valve manually a few times	
	Marks on the valve seat	Dismantle the valve and regrind the valve seat with very fine abrasive.	
Pump stopped	Pump overload relay has acted	Check the motor current Check the relay setting	
	Pump shaft seized	Maintenance to the pump	
Pressure safety switch operates	Pressure limit switch set too high	Adjust the pressure limit switch	
	Pressure limit switch faulty	Replace the pressure limit switch	
	Pressure switch pipe coil blocked	Clean or replace the pipe coil	
Safety level 1 or 2 operates	Water level detection interrupted	Steel probe encrusted Connection cable interrupted	
	Safety level relay faulty	Temporary replacement of the safety electronic relay with one of the two relays in the panel. If the problem disappears, replace the faulty relay.	
	No water feed	See faults "feed water"	
Feed water insufficient	Pump seized	See faults "Pump stopped"	
	Pump suction filter blocked	Clean the filter	
	Level control faulty	Temporary replacement of the electronic control relay with one of those present in the panel. If the problem disappears, replace the faulty relay.	
	Level probes short circuited	Dismantle the control probes for inspection of the ceramic insulation	
	Pump cavitation	Suction head (difference in height between supply tank and pump) insufficient in relation to the water temperature	Clean the pump suction filter Reduce the head loss in the pipe between collector tank and the pump by increasing the pipe section
		Pump rotation direction	Invert two phases (three-phase pump)
Burner always ON	Erroneous electrical connection to the panel	Consult the wiring diagram	
	Safety level relays faulty	See "Intervention safety level 1 or 2"	
	Control and/or safety pressure switches inactive	Check the adjustment of the pressure switches Check the pressure switch connections to the control panel	
Burner always OFF	Problems with the burner	See the specific burner Manual	
	Burner fuses interrupted	Replace the fuses	
	No consent to the burner from the control pressure switch	Replace the control pressure switch	
	No consent to the burner from the safety level relay	See "Intervention safety level 1 or 2"	
	Erroneous connection to the control panel	Consult the wiring diagram	

8 WATER LEVEL LIMITS

8.1 GENERAL

The water level limits consists in: n. 2 level rods, n. 2 probes, electrical cables, n. 2 electronic relays. The device prevents the lowering of the level of water in the steam generators and the consequent overheating of the membrature.

The principle of survey and control of the level is based on water conductivity. In order to guarantee the correct operation of the device, following conditions must be fulfilled:

- **Water conductivity** > 250 $\mu\text{S/cm}$
- **Water temperature** < 210°C
- **Pressure** < 20 bar

(See. " Operating water " - Tab. 2).

EXAMPLE: PROBES TANK FOR SAFETY AND REGULATION

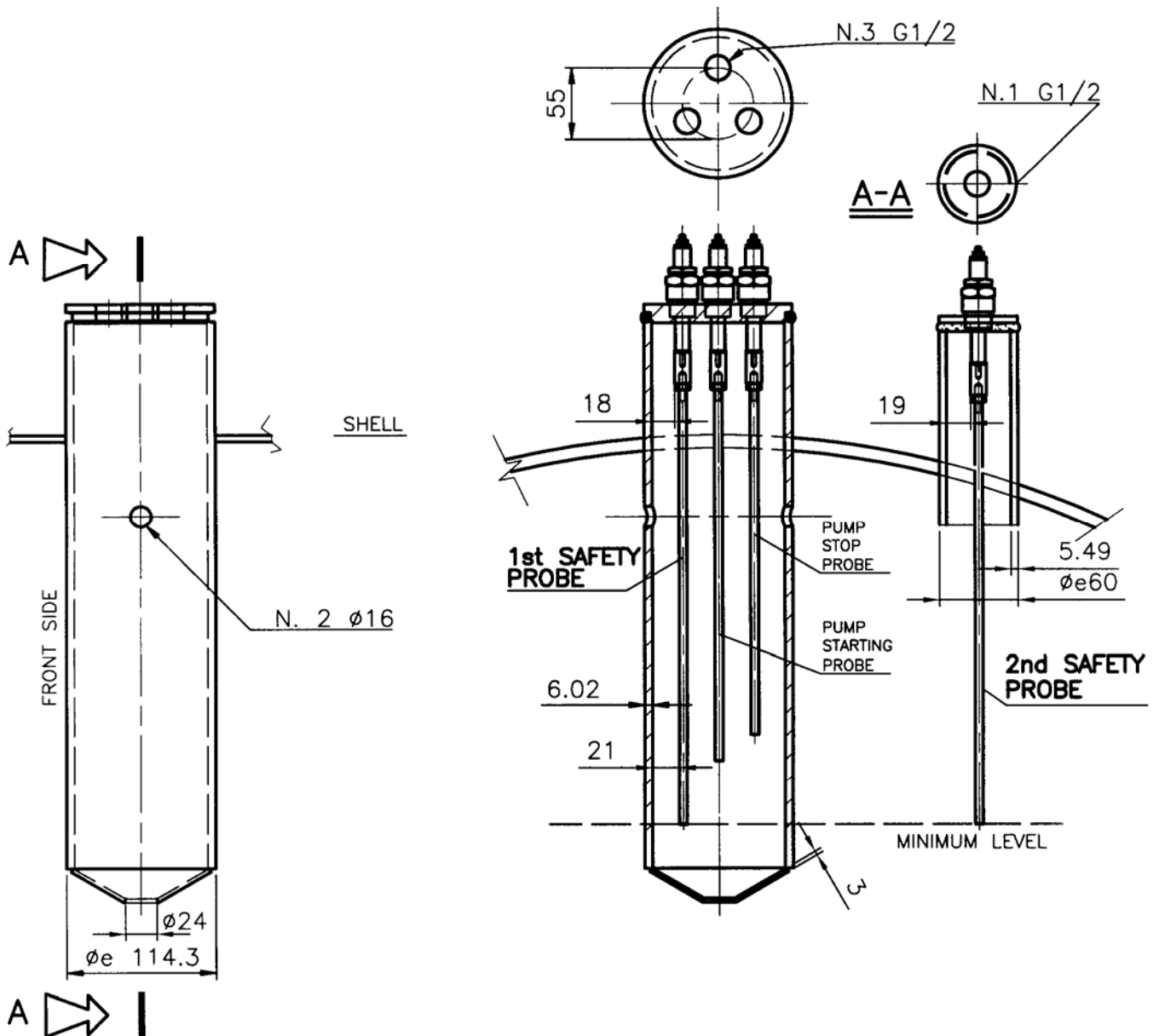

WATER LEVEL LIMITS

8.2 TYPICAL APPLICATIONS

Boiler probes:

- 6 Pump stop
- 7 Pump starting
- 8 1st burner cut-out safety device and alarm ON.
- 9 2nd burner cut-out safety device and alarm ON

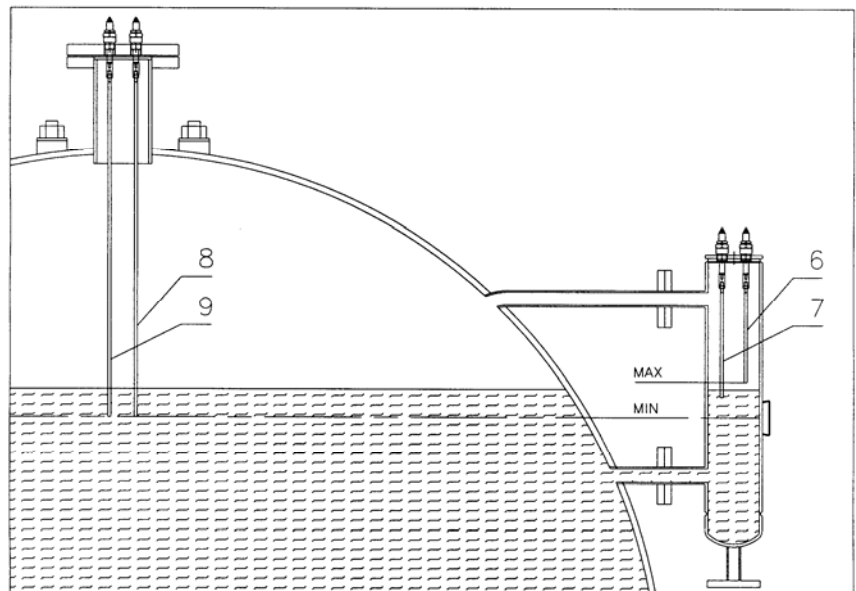
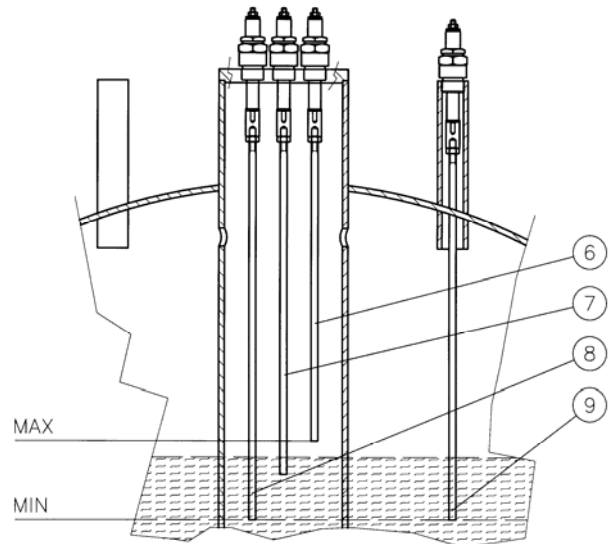

NOTE: it is recommended that an alarm bell is installed in the boiler room as well as a sound or visual alarm in highly visited rooms.

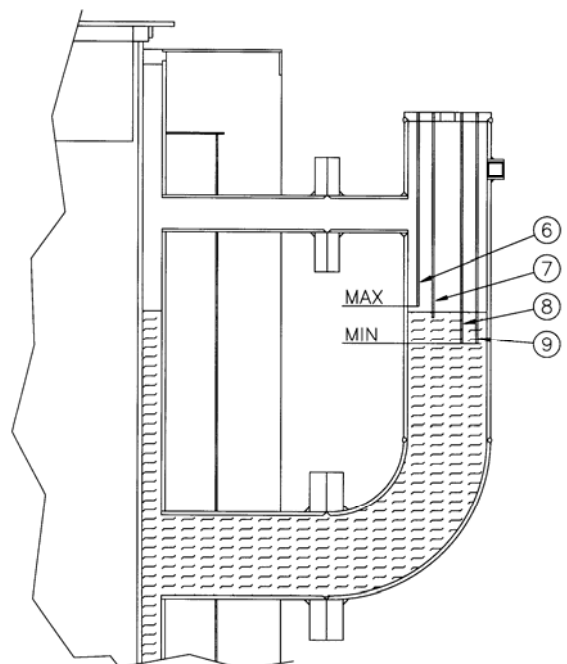

8.3 ELECTRICAL CONNECTIONS

Refer to the diagram supplied with the specific switchboard.

8.4 STEAM GENERATOR OPERATION

(Water level limits)

8.5 FIRST START-UP

- Start the boiler, as follows:
 - 1 Power up the boiler control panel
 - 2 Make sure that the motor-driven pump drive shaft is free to rotate and that rotation direction is correct.
 - 3 Set the pump selector switch on AUT and verify that burner cannot start before the attainment of the minimum level;
 - 4 Make sure that the pump stops when the maximum level is reached, observing level indicators and checking the position of their cocks;
 - 5 Maintain safety level reset pressed for 10 sec because it is employed an electronic delayed relay
 - 6 Open the boiler discharge and check on the level indicator the intervention point of probe pump start
 - 7 Set the pump selector switch on "0", leaving the discharge open, and check the intervention level of safety probes, referring to the minimum level information plate;
 - 8 Close the discharge, place pump selector switch to AUT;

8.6 MAINTENANCE

8.6.1 Ordinary

- Bleed periodically (level indicators, probe-holder barrel if any, boiler) to avoid mud deposits.
- Check the efficiency of the regulation and control instruments by inspecting carefully the electrical (also connections); it is also recommended that the probe-holder ceramic plugs are replaced every year

8.6.2 Periodic control (every 6 hours of use)

From time to time (every 6 hours of use) the thermal plant must be inspected by qualified personnel to check the efficiency of all safety accessories:

- Water level limits
- Safety valve

The system can be reset if no anomalies have been encountered: power off the panel for approx. 20 seconds, power on the main switch and press the reset buttons.

For further details follow the flow chart below:

WATER LEVEL LIMITS

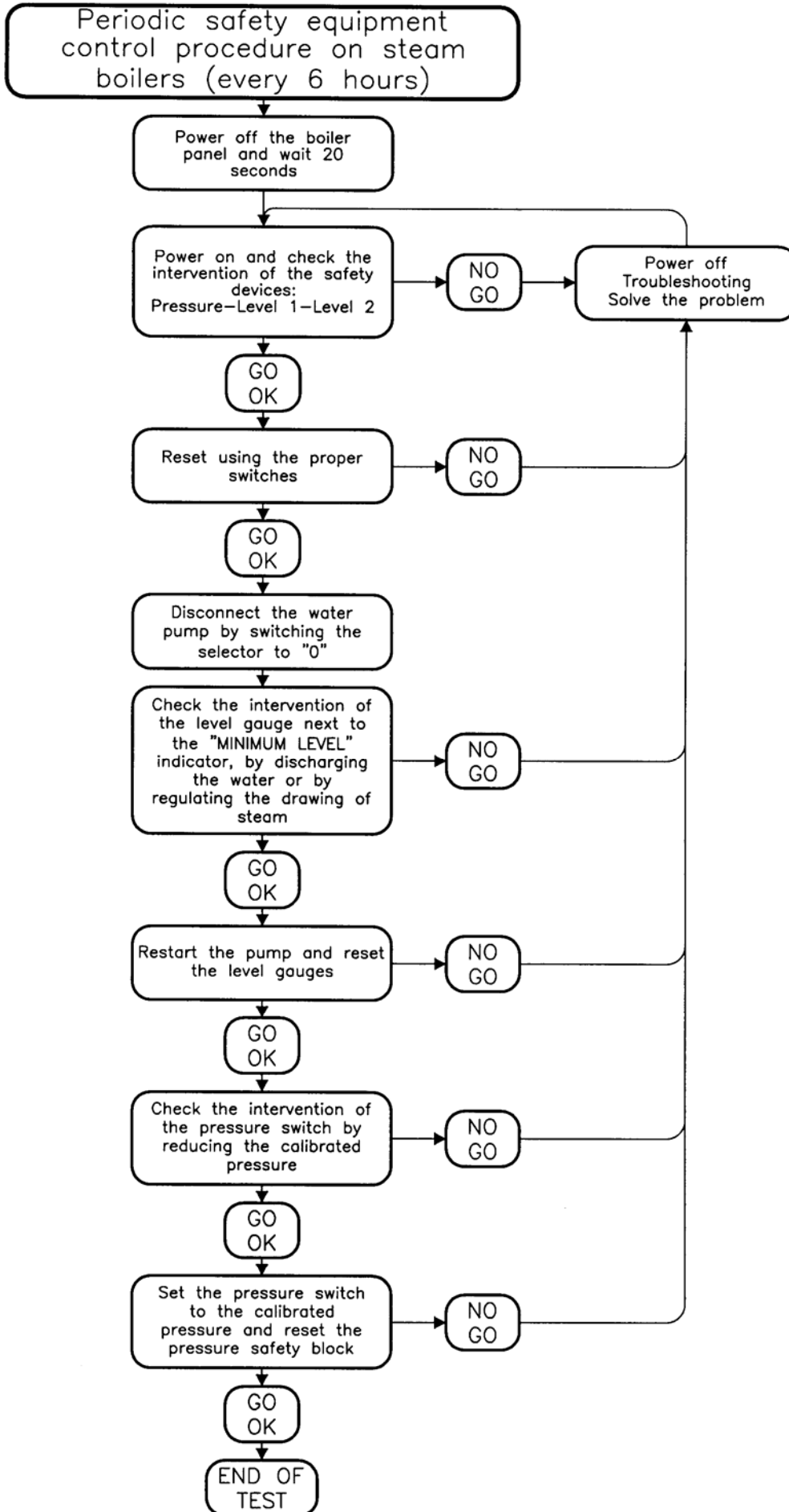

WATER LEVEL LIMITS

8.6.3 Extraordinary maintenance (water level limits substitution)

To replace the water level limits or parts of it, follow strictly the instructions below:

1. Ensure that the new ceramic plug is intact
2. Check the length of the rod
3. Ensure that the rod is coaxial to the plug axis
4. Inspect the electrical system and, in particular, ensure that the resistance of the electric circuit linking the ceramic plug to the electrical panel is intact (resistance must be over 10 MOhm)
5. Ensure that the automatic level control consisting of the two ceramic plugs and their conductivity-relays, work well

8.7 TROUBLESHOOTING

FAULT	POSSIBLE CAUSE	RECOMMENDED REMEDY	
Safety intervention level 1 or 2	Interrupted water level monitoring	Scaled stainless steel bar Broken connection cable	
	Faulty safety level relay	Temporary replace the safety electronic relay with one of the two relays in the panel. If this is the problem, replace definitively the faulty relay.	
	Water does not load	See "Loading" inconv.	
Insufficient water load	Blocked pump	See. "Blocked pump" inconv.	
	Dirty pump sucking filter	Clean the filter	
	Level regulation anomaly	Temporary replace the safety electronic relay with one of the two relays in the panel. If this is the problem, replace definitively the faulty relay.	
	Level regulation probes short circuit	Dismantle the adjustment probes to inspect visually the ceramic insulation	
	Pump cavitation	Insufficient head (=different height between the collecting vessel and the pump levels) in comparison with water temperature	Clean the pump sucking filter
		Decrease the pipe resistance between the collecting vessel and the pump by increasing the passage section	
Pump sense of rotation	Invert one of the two phases (three-phase pump)		
Burner always on	Incorrect electrical panel connection	Consult the electric diagram	
	Faulty level safety relays	See "Safety intervention level 1 or 2"	
	Regulation pressure and/or safety switches OFF	Check the pressure switches regulation Check the pressure switches connection to the electrical panel	
Burner always off	Burner problems	See burner manual	
	Interrupted burner fuses	Replace fuses	
	Lack of burner consent from the regulation pressure switch	Replace regulation pressure switch	
	Lack of burner consent from the level safety relays	See "Safety intervention level 1 or 2"	
	Incorrect electrical panel connection	Consult the electric diagram	

WATER LEVEL LIMITS

8.8 DATA LABEL

	ICI CALDAIE S.p.A. Via G. Pascoli, 38 - S.S. 434 km 9 37059 ZEVIO/Fraz. Campagnola VERONA - ITALIA Tel. 045/8738511 -fax 045/8731148
LIVELLOSTATO DI SICUREZZA WATER LEVEL LIMITS	
Modello / Model	GP1
N.fabb. / <i>Serial number</i>	
Conducibilità dell'acqua <i>Water conductivity</i>	> 250 μ S/cm
PS max	20 bar
TS max	210°C
Fluido / <i>Fluid</i>	Acqua / <i>Water</i>
Data/ <i>Date</i>	
Volt / Freq. / Pot. - <i>Power</i>	24 VAC / 50-60 Hz / 3 VA
Omologazione/ <i>Approval</i>	 0062
IL LIVELLOSTATO DI SICUREZZA DEVE ESSERE VERIFICATO OGNI 6 ORE DI FUNZIONAMENTO WATER LEVEL LIMIT SHALL BE TESTED PERIODICALLY FOR A MAX OF 6 HOURS (ved. MANUALE TECNICO/see <i>TECHNICAL MANUAL</i>)	

Boiler serial number

Boiler final test date



Appartenente al Gruppo Finluc, iscritto R.I. VR n. 02245640236

Via G. Pascoli, 38 - 37059 Zevio - fraz. Campagnola - VERONA - ITALIA

Tel. 045/8738511 - Fax 045/8731148

info@icicaldaie.com - www.icicaldaie.com

The data reported are indicative only and are not binding. Our company reserves the right to introduce alterations at any time, as it deems fit and proper for the development of the product.